

SONY®

VAIO® Z505 SuperSlim Pro™ Notebook User Guide



VAIO®

VAIO Z505
SuperSlim Pro™ Notebook
User Guide

PCG-Z505LS
PCG-Z505LSK
PCG-Z505LE
PCG-Z505LEK

SONY®

SONY

***VAIO® Z505 SuperSlim
Pro™ Notebook User
Guide***

PCG-Z505LE/PGC-Z505LEK/PCG-Z505LS/PCG-Z505LSK

Notice to Users

© 2000 Sony Electronics Inc. All rights reserved. This manual and the software described herein, in whole or in part, may not be reproduced, translated, or reduced to any machine-readable form without prior written approval.

SONY ELECTRONICS INC. PROVIDES NO WARRANTY WITH REGARD TO THIS MANUAL, THE SOFTWARE, OR OTHER INFORMATION CONTAINED HEREIN AND HEREBY EXPRESSLY DISCLAIMS ANY IMPLIED WARRANTIES OF MERCHANTABILITY OR FITNESS FOR ANY PARTICULAR PURPOSE WITH REGARD TO THIS MANUAL, THE SOFTWARE, OR SUCH OTHER INFORMATION. IN NO EVENT SHALL SONY ELECTRONICS INC. BE LIABLE FOR ANY INCIDENTAL, CONSEQUENTIAL, OR SPECIAL DAMAGES, WHETHER BASED ON TORT, CONTRACT, OR OTHERWISE, ARISING OUT OF OR IN CONNECTION WITH THIS MANUAL, THE SOFTWARE, OR OTHER INFORMATION CONTAINED HEREIN OR THE USE THEREOF.

Sony Electronics Inc. reserves the right to make any modification to this manual or the information contained herein at any time without notice. The software described herein is governed by the terms of a separate user license agreement.

This product contains software owned by Sony and licensed by third parties. Use of such software is subject to the terms and conditions of license agreements enclosed with this product. Some of the software may not be transported or used outside the United States. Software specifications are subject to change without notice and may not necessarily be identical to current retail version.

Updates and additions to software may require an additional charge. Subscriptions to online service providers may require a fee and credit card information. Financial services may require prior arrangements with participating financial institutions.



As an ENERGY STAR Partner, Sony Corporation has determined that this product meets the ENERGY STAR guidelines for energy efficiency.

The International ENERGY STAR Office Equipment Program is an international program that promotes energy saving through the use of computers and other office equipment. The program backs the development and dissemination of products with functions that effectively reduce energy consumption. It is an open system in which business proprietors can participate voluntarily. The targeted products are office equipment such as computers, displays, printers, facsimiles and copiers. Their standards and logos are uniform among participating nations. ENERGY STAR is a U.S. registered mark.

Sony, i.LINK, Memory Stick, Memory Stick logo, MG Memory Stick, DVGate, Jog Dial, Mavica, MagicGate, OpenMG Jukebox, VisualFlow, Handycam, Media Bar, MovieShaker, PictureGear, VAIO and the VAIO logo are trademarks of Sony Corporation. Windows Millennium Edition, Windows, Windows NT, and the Windows logo are registered trademarks of Microsoft Corporation. Intel, SpeedStep, and Pentium are trademarks of Intel Corporation. PS/2 is a registered trademark of IBM.

All other trademarks are trademarks of their respective owners.

Owner's Record

The model number and serial number are located on the bottom of your Sony VAIO® Z505 SuperSlim Pro™ notebook. Record the serial number in the space provided here. Refer to the model and serial number when you call your Sony Service Center.

Model Number: PCG-531A, PCG-5312,
PCG-532A, PCG-5322

Serial Number: _____

Safety Information

WARNING

- To prevent fire or shock hazard, do not expose your notebook to rain or moisture.
 - To avoid electrical shock, do not open the cabinet. Refer servicing to qualified personnel only.
 - Never install modem or telephone wiring during a lightning storm.
 - Never install telephone jacks in wet locations unless the jack is specifically designed for wet locations.
 - Never touch uninsulated telephone wire or terminals unless the telephone line has been disconnected at the network interface.
 - Use caution when installing or modifying telephone lines.
 - Avoid using the modem during an electrical storm.
- Do not use the modem or a telephone to report a gas leak in the vicinity of the leak.
 - A socket outlet should be as close as possible to the unit and easily accessible.

AVERTISSEMENT

- Pour prévenir tout risque d'incendie ou d'électrocution, garder cet appareil à l'abri de la pluie et de l'humidité.
- Pour prévenir tout risque d'électrocution, ne pas ouvrir le châssis de cet appareil et ne confier son entretien qu'à une personne qualifiée.
- Ne jamais effectuer l'installation de fil modem ou téléphone durant un orage électrique.
- Ne jamais effectuer l'installation d'une prise téléphonique dans un endroit mouillé à moins que la prise soit conçue à cet effet.
- Ne jamais toucher un fil téléphonique à découvert ou un terminal à moins que la ligne téléphonique n'ait été débranché de l'interface réseau.
- Soyez très prudent lorsque vous installez ou modifiez les lignes téléphoniques.
- Évitez d'utiliser le modem durant un orage électrique.
- N'utilisez pas le modem ni le téléphone pour prévenir d'une

fuite de gaz si vous êtes près de la fuite.

- ❑ L'appareil doit être le plus près possible d'une prise murale pour en faciliter l'accès.

! Caution: To reduce the risk of fire, use only No. 26 AWG or larger telecommunication line cord.

! Attention : Afin de réduire les risques d'incendie, n'utilisez qu'un cordon de communication NO. 26 AWG ou plus gros.

Regulatory Information

If you have any questions about this product, you can reach the Sony Customer Information Service Center at 1-888-4SONYPC; or write to the Sony Customer Information Service Center at 12451 Gateway Blvd., Ft. Meyers, FL 33913, or find Sony Customer Service on the Web at: <http://www.sony.com/pcsupport>.

Declaration of Conformity

Trade Name:	SONY
Model No.:	PCG-531A, PCG-5312, PCG-532A, PCG-5322
Responsible Party:	Sony Electronics Inc.
Address:	1 Sony Drive Park Ridge, NJ 07656
Telephone:	201-930-6972

This phone number is for FCC-related matters only.

This device complies with Part 15 of the FCC rules. Operation is subject to the following two conditions:

- (1) This device may not cause harmful interference, and
- (2) this device must accept any interference received, including interference that may cause undesired operation.

This equipment has been tested and found to comply with the limits for a Class B digital device, pursuant to Part 15 of the Rules. These limits are designed to provide reasonable protection against harmful interference in a residential installation. This equipment generates, uses, and can radiate radio frequency energy and, if not installed and used in accordance with the instructions, may cause harmful interference to radio communications. However, there is no guarantee that interference will not occur in a particular installation. If this equipment does cause harmful interference to radio or television reception, which can be determined by turning the equipment off and on, the user is encouraged to try to correct the interference by one or more of the following measures:

- ❑ Reorient or relocate the receiving antenna.
- ❑ Increase the separation between the equipment and the receiver.
- ❑ Connect the equipment into an outlet on a circuit different from that to which the receiver is connected.
- ❑ Consult the dealer or an experienced radio/TV technician for help.

You are cautioned that any changes or modifications not expressly approved in this manual could void your authority to operate this equipment.

Only peripherals (computer input/output devices, terminals, printers, etc.) that comply with FCC Class B limits may be attached to this computer product. Operation with noncompliant peripherals is likely to result in interference to radio and television reception.

All cables used to connect peripherals must be shielded and grounded. Operation with cables, connected to peripherals, that are not shielded and grounded, may result in interference to radio and television reception.

FCC Part 68

This equipment complies with Part 68 of the FCC rules. On the bottom of this equipment is a label that contains, among other information, the FCC Ringer Equivalence Number (REN) for this equipment. If requested, this information must be provided to the telephone company.

This modem uses the USOC RJ-11 telephone jack.

The REN is used to determine the quantity of devices which may be connected to the telephone line. Excessive RENs on the telephone line may result in the devices not ringing in response to an incoming call. In most, but not all areas, the sum of the RENs should not exceed five (5.0). To be certain of the number of devices that may be connected to the line, as determined by the total RENs, contact the telephone company to determine the maximum REN for the calling area.

If the terminal equipment causes harm to the telephone network, the telephone company will notify you in advance that temporary discontinuance of service may be required. But if advance notice is not practical, the telephone

company will notify the customer as soon as possible. Also, you will be advised of your right to file a complaint with the FCC if you believe it is necessary.

The telephone company may make changes in its facilities, equipment, operations or procedures that could affect the operations of the equipment. If this happens, the telephone company will provide advance notice in order for you to make the necessary modifications in order to maintain uninterrupted service.

If trouble is experienced with this equipment, you can reach the Sony Customer Information Service Center at 1-888-4SONYPC; or write to the Sony Customer Information Service Center at 12451 Gateway Blvd., FL 33913, or find Sony Customer Service on the web at <http://www.sony.com/pcsupport>.

Repair of this equipment should be made only by a Sony Service Center or Sony authorized agent. For the Sony Service Center nearest you, call 1-888-4SONYPC (1-888-476-6972).

This equipment cannot be used on public coin service provided by the telephone company. Connection to Party Line Service is subject to state and possible provincial tariffs. (Contact the state or provincial utility service commission, public service commission, or corporation commission for information.)

Telephone Consumer Protection Act of 1991 (United States)

The Telephone Consumer Protection Act of 1991 makes it unlawful for any person to use a computer or other electronic device to send any message via a telephone facsimile machine unless such message clearly contains, in a margin at the top or bottom of each transmitted page or on the first page of the transmission, the date and time it is sent and an identification of the business, other entity, or individual sending

the message, and the telephone number of the sending machine or such business, other entity, or individual.

In order to program this information into your facsimile machine, see your fax software documentation.

Telephone Consumer Guidelines (Canada)

Please refer to your telephone directory under 'Privacy Issues' and/or 'Terms of Service.' For more detailed information, please contact:

CRTC

Terrasses de la Chaudière, Tour centrale
1 promenade du Portage, 5 étage Hull PQ K1A 0N2.

This Class B digital apparatus complies with Canadian ICES-003.

Cet appareil numérique de la classe B est conforme à la norme NMB-003 du Canada.

DISPOSAL OF LITHIUM ION BATTERY

You can return your unwanted lithium ion batteries to your nearest Sony Service Center or Factory Service Center.



In some areas the disposal of lithium ion batteries in household or business trash may be prohibited.

For the Sony Service Center nearest you, call 1-888-476-6972 in the United States or 1-800-961-7669 in Canada.

! Do not handle damaged or leaking lithium ion batteries.

! Ne pas manipuler les batteries au lithium-ion qui fuient ou sont endommagées.

! Danger of explosion if battery is incorrectly replaced. Replace only with the same or equivalent type recommended by the manufacturer. Discard used batteries according to the manufacturer's instructions.

! Une batterie non conforme présente un danger d'explosion. La remplacer seulement par une batterie identique ou de type équivalent recommandé par le fabricant. Évacuer les batteries usées selon les directives du fabricant.

- ! **The battery pack used in this device may present a fire or chemical burn hazard if mistreated. Do not disassemble, heat above 212°F (100°C) or incinerate. Dispose of used battery promptly. Keep away from children.**
- ! **La manutention incorrecte du module de batterie de cet appareil présente un risque d'incendie ou de brûlures chimiques. Ne pas démonter, incinérer ou exposer à une température de plus de 100°C. Évacuer promptement la batterie usée. Garder hors de portée des enfants.**

INDUSTRY CANADA NOTICE

NOTICE: The Industry Canada label identifies certified equipment. This certification means that the equipment meets certain telecommunications network protective, operational and safety requirements as prescribed in the appropriate Terminal Equipment Technical Requirements document(s). The Department does not guarantee the equipment will operate to the user's satisfaction.

Before installing this equipment, users should ensure that it is permissible to be connected to the facilities of the local telecommunications company. The equipment must also be installed using an acceptable method of connection.

The customer should be aware that compliance with the above conditions may not prevent degradation of service in some situations.

Repairs to certified equipment should be coordinated by a representative designated by the supplier. Equipment malfunctions or any

repairs or alterations made by the user to this equipment may give the telecommunications company cause to request that the user disconnect the equipment.

Users should ensure for their own protection that the electrical ground connections of the power utility, telephone lines and internal metallic water pipe system, if present, are connected together. This precaution may be particularly important in rural areas.

CAUTION: Users should not attempt to make such connections themselves, but should contact the appropriate electrical inspection authority, or electrician, as appropriate.

NOTICE: The Ringer Equivalence Number (REN) assigned to each terminal device provides an indication of the maximum number of terminals allowed to be connected to a telephone interface. The termination on an interface may consist of any combination of devices subject only to the requirement that the sum of the Ringer Equivalence Numbers of all the devices does not exceed 5. The Ringer Equivalence Number for this equipment is 1.3.

AVIS DE L'INDUSTRIE CANADA

AVIS: L'étiquette d'Industrie Canada identifie le matériel homologué.

Cette étiquette certifie que le matériel est conforme aux normes de protection, d'exploitation et de sécurité des réseaux de télécommunications, comme le prescrivent les documents concernant les exigences techniques relatives au matériel terminal. Le Ministère n'assure toutefois pas que le matériel fonctionnera à la satisfaction de l'utilisateur.

Avant d'installer ce matériel, l'utilisateur doit s'assurer qu'il est permis de le raccorder aux installations de l'entreprise locale de télécommunication. Le matériel doit également être installé en suivant une méthode acceptée de

raccordement. L'abonné ne doit pas oublier qu'il est possible que la conformité aux conditions énoncées ci-dessus n'empêche pas la dégradation du service dans certaines situations.

Les réparations de matériel homologué doivent être coordonnées par un représentant désigné par le fournisseur. L'entreprise de télécommunications peut demander à l'utilisateur de débrancher un appareil à la suite de réparations ou de modifications effectuées par l'utilisateur ou à cause de mauvais fonctionnement.

Pour sa propre protection, l'utilisateur doit s'assurer que tous les fils de mise à la terre de la source d'énergie électrique, des lignes téléphoniques et des canalisations d'eau métalliques, s'il y en a, sont raccordés ensemble. Cette précaution est particulièrement importante dans les régions rurales.

Avertissement: L'utilisateur ne doit pas tenter de faire ces raccordements lui-même; il doit avoir recours à un service d'inspection des installations électriques, ou à un électricien, selon le cas.

AVIS: L'indice d'équivalence de la sonnerie (IES) assigné à chaque dispositif terminal indique le nombre maximal de terminaux qui peuvent être raccordés à une interface.

La terminaison d'une interface téléphonique peut consister en une combinaison de quelques dispositifs, à la seule condition que la somme d'indices d'équivalence de la sonnerie de tous les dispositifs n'excède pas 5.

L'indice d'équivalence de la sonnerie de ce matériel est de 1.3.

Contents

Welcome.....	11
Features	11
Unpacking Your Notebook	12
Ergonomic Considerations	14
Setting Up Your VAIO® Notebook	17
Locating Controls and Connectors	17
Connecting a Power Source	21
Starting Your Computer	27
Shutting Down Your Computer	28
Using the Keyboard.....	29
Using the Touchpad	34
Using the Floppy Disk Drive	35
Connecting the CD/DVD Drive (optional)	38
Using PC Cards	42
Using Smart Connect	46
Connecting an i.LINK® device.....	47
VAIO Action Setup.....	50
The Jog Dial™ Control	50
Using Memory Stick® Media.....	53
Using Power Saving Modes	56

Connecting Peripheral Devices59

- Connecting a Phone Line (optional) 60
- Connecting to the Local Area Network (LAN) 62
- Connecting the i.LINK® Port Replicator 63
- Connecting an External Display 66
- Connecting a Universal Serial Bus (USB) Device ... 71
- Adding Memory 73

About the Software on Your Computer...79

Software Information83

- MovieShaker™ 83
- PictureGear™ 86
- For Answers to Your Software Questions 88

**Using the System and
Application Recovery CDs91**

Troubleshooting.....95

- Getting Help..... 107

Specifications..... 109

Index..... 113

Welcome

Congratulations on your purchase of the Sony VAIO® notebook. Sony has combined leading-edge technology in audio, video, computing, and communications to provide you with state-of-the-art personal computing.

Features

 For a complete description of the specifications of your VAIO Z505 SuperSlim Pro Notebook, see page 109

- ❑ **Exceptional performance** — Your notebook includes a Mobile Intel® Pentium® III processor featuring Intel® SpeedStep™ technology and a V.90-compatible K56flex modem.*
- ❑ **Portability** — Rechargeable battery pack provides hours of use without AC power.
- ❑ **Sony audio and video quality** — High-quality MPEG1 video, which supports full-screen display (12.1-inch Active Matrix LCD screen) and enables you to take advantage of today's advanced multimedia applications, games, and entertainment software.
- ❑ **Microsoft Windows® operating system** — Your system includes Microsoft® Windows® Millennium Edition or Microsoft® Windows® 2000 Professional.
- ❑ **Communications** — Access popular online services, send e-mail, browse the Internet, and use fax features.

* Actual upload and download speeds may vary due to line conditions, ISP support, and government regulations.

Unpacking Your Notebook

Remove the following hardware items from the box:

Main unit

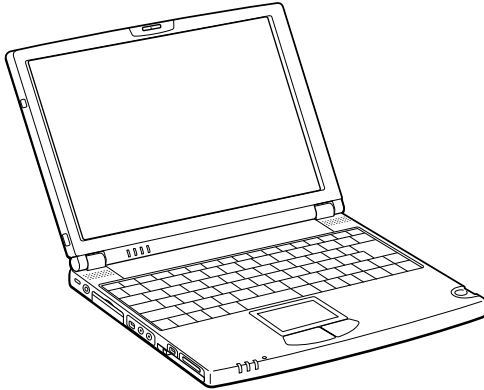

Power cord

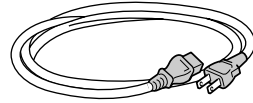

AC adapter

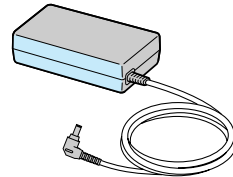

USB conversion adapter



Rechargeable battery pack

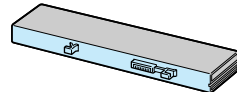

i.LINK port replicator

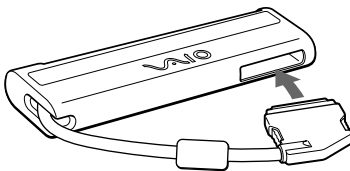

USB floppy disk drive



Manuals

- ❑ **VAIO® User Guide** — Features and specifications of your computer. It also includes information on the applications included with your system and how to contact software vendors, and solve common problems.

Operating System Getting Started

- ❑ **Microsoft® Windows® Millennium Edition Getting Started manual or the Microsoft® Windows® 2000 Professional Getting Started manual** — Explains how to use the basic features of this latest Windows operating system.

Software CDs

- ❑ **Microsoft® Word 2000** — Allows you to reinstall Microsoft Word 2000 to the Sony computer you purchased.

Recovery CDs

- ❑ **System Recovery CD(s)** — Allows you to restore the software titles that shipped with your computer if they become corrupted or are erased. It can be used only to restore the hard disk of the Sony computer you purchased.
- ❑ **Application Recovery CD(s)** — Allows you to reinstall individual applications or device drivers if they are corrupted or erased.

 To use these recovery CDs, you need to purchase either the PCG-CD51/A CD-ROM drive or the PCGA-DVD51/A DVD drive.

Other

- ❑ Setting up your VAIO® Notebook (poster)
- ❑ Packet containing special product offers

Ergonomic Considerations

You will be using your notebook computer as a portable device in a variety of environments. Whenever possible, you should attempt to apply the following ergonomic considerations to both stationary and portable environments.

Recommended position

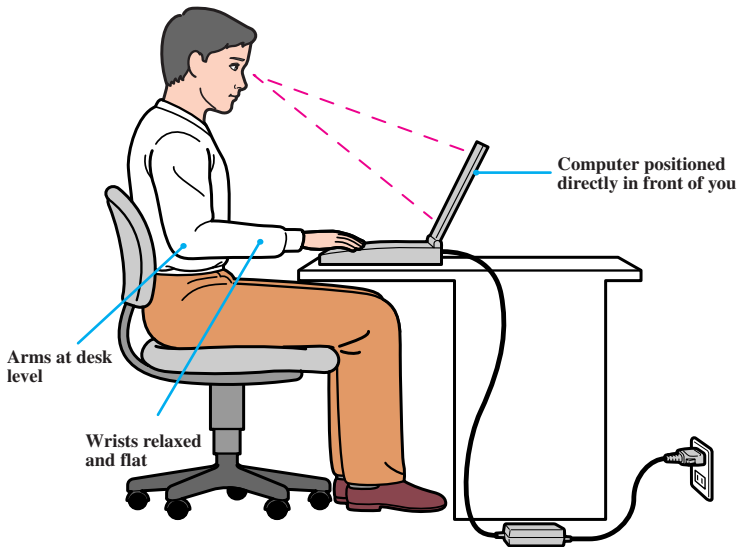

- ❑ **Position of your computer** — Place the computer directly in front of you as you work. Keep your forearms horizontal, with your wrists in a neutral, comfortable position while using the keyboard, touchpad, or external mouse. Let your upper arms hang naturally at your sides. Take breaks during sessions with your computer. Excessive use of the computer may strain muscles or tendons.
- ❑ **Furniture and posture** — Sit in a chair with good back support and armrests. Adjust the level of the chair so your feet are flat on the floor. A footrest may make you more comfortable. Sit in a relaxed, upright posture and avoid slouching forward or leaning far backward.
- ❑ **Viewing angle of the computer's display** — Use the display's tilting feature to find the best position. You can reduce eye strain and muscle fatigue by adjusting the tilt of the display to the proper position. Adjust the brightness setting of the display also.

- ❑ **Lighting** — Choose a location where windows and lights do not create glare and reflection on the display. Use indirect lighting to avoid bright spots on the display. You can also purchase accessories for your display that help reduce glare. Proper lighting adds to your comfort and work effectiveness.
- ❑ **Placement of an external display** — When using an external display, set the display at a comfortable viewing distance. Make sure the display screen is at eye level or slightly lower when you are sitting in front of the monitor.

Notes on Setup

- ❑ Do not place your computer in a location subject to:
 - ❑ Heat sources, such as radiators or air ducts
 - ❑ Direct sunlight
 - ❑ Excessive dust
 - ❑ Moisture or rain
 - ❑ Mechanical vibration or shock
 - ❑ Strong magnets or speakers that are not magnetically shielded
 - ❑ Ambient temperature of more than 95° F (35° C) or less than 18° F (10° C)
 - ❑ High humidity
- ❑ Do not place electronic equipment near your computer. The computer's electromagnetic field may cause a malfunction.
- ❑ Provide adequate air circulation to prevent internal heat buildup. Do not place your computer on porous surfaces such as rugs or blankets, or near materials such as curtains or draperies that may block its ventilation slots. Leave a space of at least 8 inches (20 cm) behind the back panel of the computer.
- ❑ If the computer is brought directly from a cold location to a warm one, moisture may condense inside your computer. In this case, allow at least an hour before turning on your computer. If any problems occur, unplug your computer, and contact your Sony Service Center.
- ❑ The computer uses high-frequency radio signals and may cause interference to radio or TV reception. Should this occur, relocate the computer a suitable distance away from the set.
- ❑ Use only specified peripheral equipment and interface cables; otherwise, problems may result.

- ❑ Do not use cut or damaged connection cables.
- ❑ Your computer will not work with party lines, cannot be connected to a coin-operated telephone, and may not work with multiple phone lines or a private branch exchange (PBX).
- ❑ If the telephone company makes a service call to your home or office and determines that your computer is responsible for a problem, the telephone company may bill you for the service call. Also, if you do not disconnect your computer when it is adversely affecting the telephone line, the telephone company has the right to disconnect your service until you correct the problem.

On Handling

- ❑ Clean the cabinet with a soft, dry cloth or a soft cloth lightly moistened with a mild detergent solution. Do not use any type of abrasive pad, scouring powder, or solvent such as alcohol or benzine, as these may damage the finish of your computer.
- ❑ Should any solid object or liquid fall into the computer, shut down your computer and then unplug it. You may want to have the computer checked by qualified personnel before operating it any further.
- ❑ Do not drop the computer or place heavy objects on top of the computer.

Setting Up Your VAIO® Notebook

Locating Controls and Connectors

Front

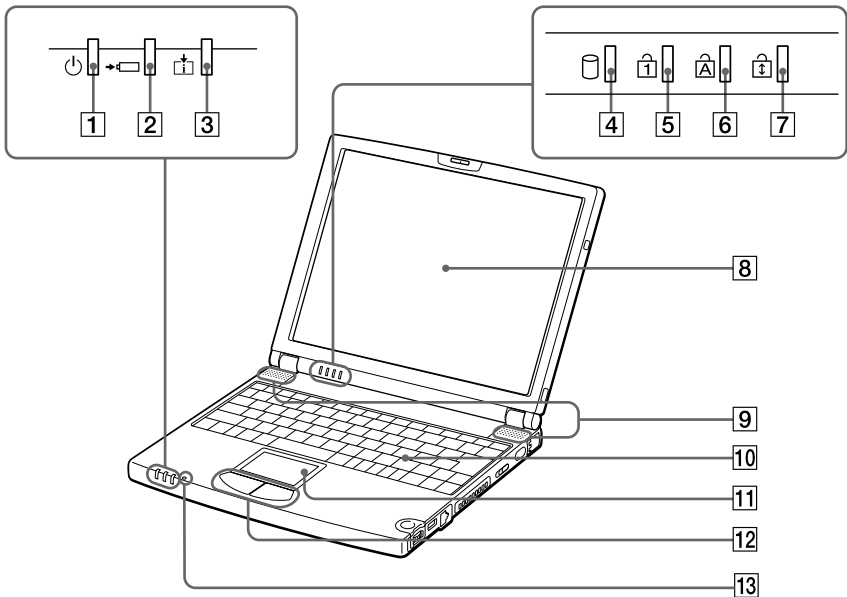

- | | |
|---|---------------------------|
| 1 | Power indicator |
| 2 | Battery indicator |
| 3 | Information indicator |
| 4 | Hard disk drive indicator |
| 5 | Num Lock indicator |
| 6 | Caps Lock indicator |
| 7 | Scroll Lock indicator |

8 LCD screen

9 Speakers

10 Keyboard

11 Touchpad

12 Left/right button

13 Microphone

Back

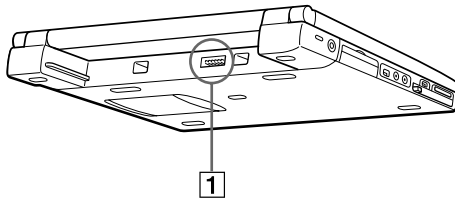

-
- 1** Battery connector
-

Left

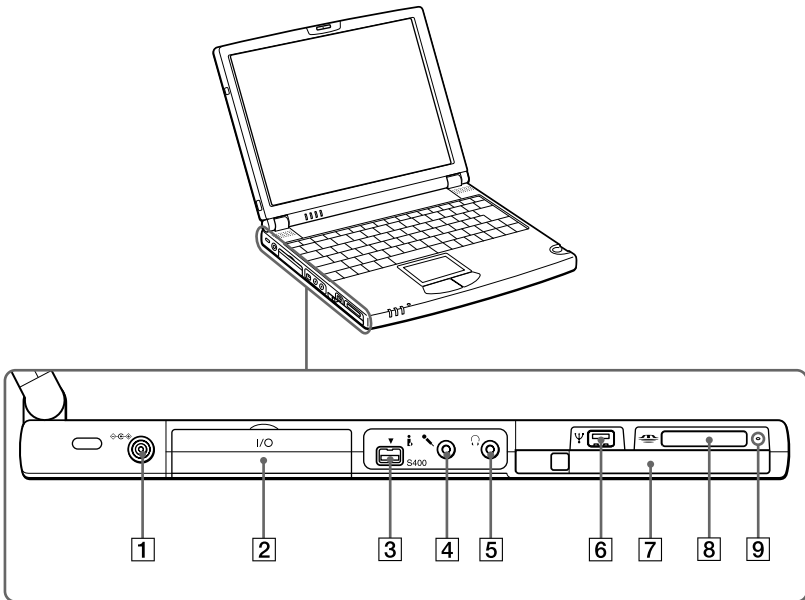



-
- 1** ⚡ DC In connector
-
- 2** I/O i.LINK® port replicator connector
-
- 3** i.LINK* (IEEE1394) S400
-
- 4** 🎤 Microphone connector
-
- 5** 🎧 Headphone connector
-

- 6 mini USB connector
- 7 PC Card slot
- 8  Memory Stick® slot
- 9 Memory Stick® indicator

* i.LINK is a trademark of Sony used only to designate that a product contains an IEEE1394 connector. All products with an i.LINK connector may not communicate with each other.

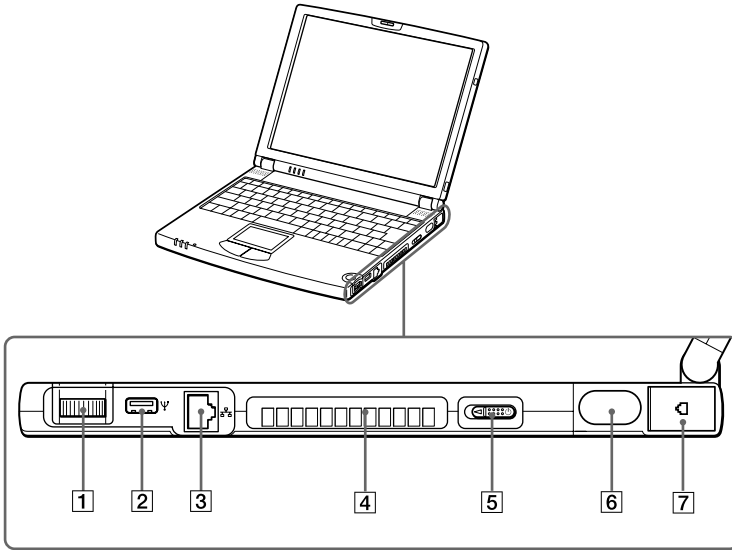
Right



- 1 Jog Dial™ control
- 2  USB connector
- 3  Ethernet port
- 4 Air vent
- 5 Power switch
- 6 Infrared port
- 7 Phone line jack

Warning: Only connect 10BASE-T and 100BASE-TX cables to the  (Ethernet network) port. Do not connect any other type of network cable or any telephone line. Connecting cables other than those listed above may result in an electric current overload and could cause a malfunction, excessive heat, or fire in the connector. To connect the unit to the network, contact your network administrator.

Bottom

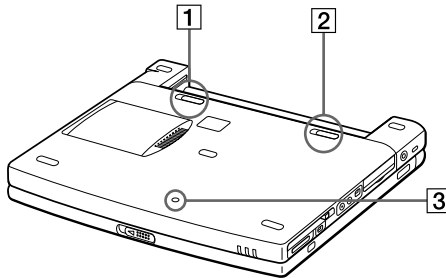

-
- | | |
|----------|-----------------------|
| 1 | Battery release lever |
| 2 | Battery lock lever |
| 3 | Reset switch |
-

Connecting a Power Source

You can use either AC power or a rechargeable battery pack as a power source.

Using the AC Adapter

- 1** Plug the cable attached to the AC adapter (PCGA-AC19V1) into the DC In connector on the computer.
- 2** Plug one end of the power cord into the AC adapter.
- 3** Plug the other end of the power cord into an AC outlet.

Connecting AC Adapter

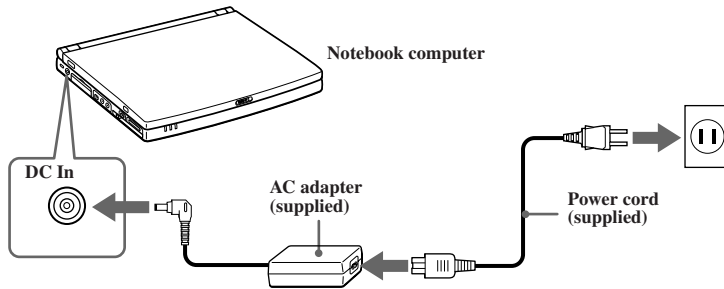

Notes on the AC Adapter

- ❑ Your computer operates on 100-240V AC 50/60 Hz.
- ❑ Do not share the AC outlet with other power-consuming equipment, such as a copy machine or shredder.
- ❑ You can purchase a power strip with a surge protector. This device prevents damage to your computer caused by sudden power surges such as those that may occur during an electrical storm.
- ❑ Do not place heavy objects on the power cord.
- ❑ To disconnect the cord, pull it out by the plug. Never pull the cord itself.
- ❑ Unplug your computer from the wall outlet if you will not be using the computer for a long time.
- ❑ When the AC adapter is not used, unplug it from the AC outlet.
- ❑ Use only the AC adapter supplied. Do not use any other AC adapter.

Using Battery Power

You can use a battery pack as a source of power. The PCGA-BPZ51 battery pack that comes with your computer is not fully charged at the time of purchase. Follow the steps below to insert and charge the battery pack.

 You can also purchase the triple-capacity PCGA-BPZ52 battery pack as a separate option. See “Using Power Saving Modes” on page 56 for power management information.

To insert the battery pack

You can insert or remove the battery pack without turning off the computer when your computer is connected to the AC adapter. Before inserting or removing a battery pack, close the cover.

- 1 Move the lock lever on the bottom of the computer to the **UNLOCK** position.

Lock Lever

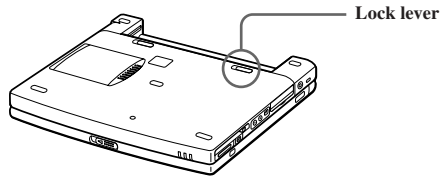

- 2 Align the grooves and tabs on the battery with the tabs and notches on the back of the computer, and then slide the battery toward the computer until it clicks into place.

Inserting Battery Pack

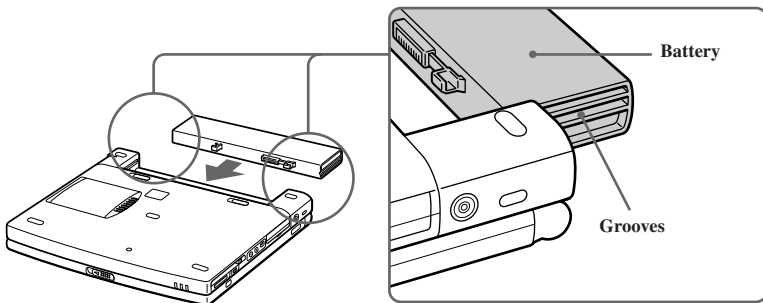

- 3 Slide the lock lever into the **lock** position to secure the battery on the computer.

To charge the battery pack

- 1 Connect the AC adapter to the computer.
- 2 Insert the battery pack.

The computer automatically charges the battery (the battery indicator light flashes in a double-blink pattern as the battery charges). When the battery is 85% full, the battery indicator light turns off. This process takes approximately one and one half hours. To charge the battery completely, continue charging for an additional hour.

The  battery indicator light on the front of the computer indicates the status of the battery pack.

Battery indicator light

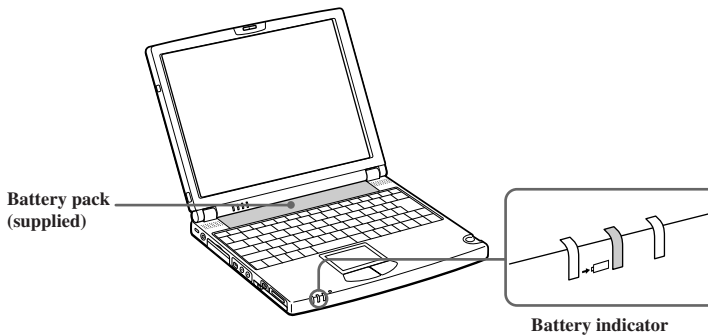

Battery Indicator Light Status	Meaning
On	The computer is using battery power.
Single blink	The battery is running out of power.
Double blink	The battery is charging.
Off	The computer is using AC power.

 Both the battery and power indicators blink when the battery is running out of power.

To remove the battery pack

You can insert or remove the battery pack without turning off the computer when your computer is connected to the AC adapter. Before inserting or removing a battery pack, close the cover.

- 1 Turn off the computer and close the cover.
- 2 Slide the lock lever to the **UNLOCK** position.
- 3 Slide the release lever to the **UNLOCK** position and slide the battery away from the computer.

Removing battery pack

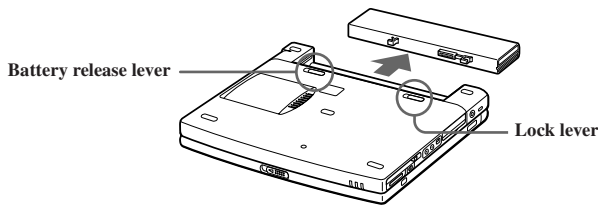

 You may lose data if you remove the battery pack while the computer is on and not connected to the AC adapter or if you remove the battery while the computer is in a power saving mode.

Additional Notes On Batteries

- ❑ Keep the battery pack in the computer while it is directly connected to AC power. The battery pack continues to charge while you are using the computer.
- ❑ If your battery level falls to less than 10%, you should either attach the AC adapter to recharge the battery or shut down your computer and insert a fully-charged battery.
- ❑ You can extend battery life by changing the power management modes in the PowerPanel utility. See “Using Power Saving Modes” on page 56.
- ❑ The battery pack supplied with your computer is a lithium ion battery and can be recharged at any time. Charging a partially discharged battery does not affect battery life.

- ❑ The battery indicator light is on while you use the battery pack as a power source. When battery life is nearly depleted, the battery indicator starts flashing.
- ❑ Your computer may not enter System Hibernation mode when the battery life is low if certain software applications are active or if certain peripheral devices are connected. To avoid loss of data when using battery power, you should save your data frequently and manually activate a power management mode, such as System Suspend or System Hibernation.
- ❑ Never leave the battery pack in temperatures above 140° F (60° C), such as under direct sunlight or in a car parked in the sun.
- ❑ Battery life is shorter in a cold environment. This is due to decreased battery efficiency at low temperatures.
- ❑ Charge the batteries at temperatures between 50° F and 80° F (10° C to 30° C). Lower temperatures require a longer charging time.
- ❑ While the battery is in use or being discharged, the battery pack heats up. This is normal and is not cause for concern.
- ❑ Keep the battery pack away from all sources of heat.
- ❑ Keep the battery pack dry.
- ❑ Do not open or try to disassemble the battery pack.
- ❑ Do not expose the battery pack to any mechanical shock.
- ❑ If you are not using the computer for an extended period of time, remove the battery pack from the computer to prevent damage to the battery.
- ❑ If, after fully charging the battery pack, the battery power is still low, the battery pack may be reaching the end of its life and should be replaced.
- ❑ You do not need to discharge the battery before recharging.
- ❑ If you have not used the battery pack for a considerable amount of time, recharge the battery.

Starting Your Computer

- 1 Slide the LCD lock lever in the direction of the arrow, and lift the cover.

Opening

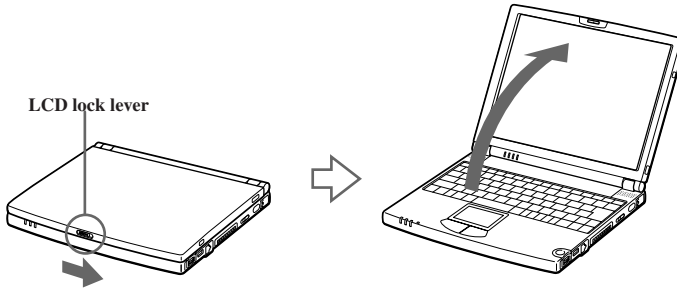

- 2 Slide the power switch on the right side toward the front of the computer until the green power indicator light turns on.

 (Windows Me only) When starting your notebook for the first time, the VAIO InitManager dialog box will appear. Please select "OK" to begin initial setup. If you do not execute the initial setup, you cannot use part of VAIO original hardware functions such as Jog Dial, Power Management tool, scroll function of touchpad, and keyboard shortcut key function combined with the Fn key.

Turning on Computer

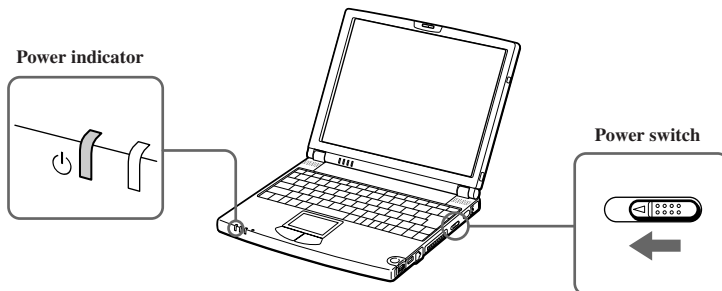

 If you hold the power switch in the On position for more than four seconds, the computer turns off.

- 3 If necessary, adjust the brightness controls for the LCD display. To decrease the brightness, press Fn+F5 and then the down or left arrow key. To increase the brightness, press Fn+F5 and then the up or right arrow key.

Shutting Down Your Computer

To avoid potential loss of data, follow these steps to shut down your computer.

- 1 Click the Start button on the Windows® taskbar.
- 2 Click Shut Down at the bottom of the Start menu to display the Shut Down Windows dialog box.
- 3 Select Shut down.
- 4 Click OK.

 Respond to any prompts warning you to save documents.

- 5 Wait for your computer to turn off automatically. The power indicator turns off.
- 6 Turn off any peripherals connected to your computer.

 During a period of inactivity, you can conserve battery life by using System Suspend mode. See “Controlling Power Management” in the online manual *Customizing Your VAIO® Notebook*.

If you are unable to shut down your computer:

- 1 Close or end all operations.
 - Close all applications.
 - Remove the PC cards.
 - Disconnect USB devices.
 - End Infrared Communication.
- 2 Then, restart the computer. You can restart your computer by pressing Ctrl+Alt+Delete keys (at the same time).

 If you are still unable to shut down the computer, you can press the power button and hold it for four seconds. This operation may result in data loss.



Using the Keyboard

Your keyboard is very similar to a typewriter's, but the keyboard has additional keys that perform specific computer-related tasks.

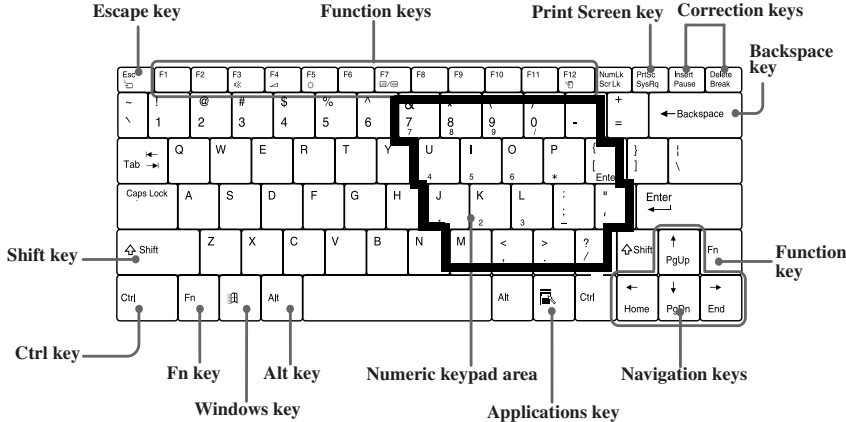





Keyboard





Key	Description
Numeric keypad area	Contains the keys found on a typical calculator. Use the numeric keypad area to type numbers or to perform mathematical calculations such as addition and subtraction. Note that you must press the Num Lock key to activate the numeric keypad. (When you do so, the Num Lock light will be on.)
Navigation keys	Several keys are devoted to moving the cursor on the screen (the four arrow keys which also function as the Home, End, Page Up, and Page Down keys).
Correction keys	The Insert, Back Space, and Delete keys enable you to make corrections in your documents.
Function keys	The 12 function keys along the top of the keyboard are used to perform designated tasks. For example, in many applications, F1 is the Help key. The task associated with each function key may vary from one application to the next.
Escape key	The Esc (Escape) key is used to cancel commands.





Key	Description
Print Screen key	The Print Screen key takes an electronic snapshot of the screen and places it in the Windows Clipboard. You can then paste the screen shot into a document and print it.
Operator keys	Several keys are always used with at least one other key: Ctrl, Alt, and Shift. When held down with another key, the Ctrl (Control) and Alt (Alternate) keys offer another way to give commands. For example, in many applications, instead of choosing the Save command from a menu, you can hold down Ctrl and press S (referred to as Ctrl+S). The Shift key operates the same way as on a typewriter; it is used to produce capital letters or special symbols such as @ and \$.
Windows key 	The key with the Windows logo displays the Windows Start menu; it is the equivalent of clicking the Start button on the task bar. See “Combinations and Functions with the Windows Key” on page 30.
Fn key	The Fn key is used in combination with other keys to issue commands. The Fn keys at the left and right sides both work the same. See “Combinations and Functions with the Fn Key” on page 32.
Applications key 	The Applications key displays a shortcut menu of context-sensitive choices; pressing this key is the equivalent of clicking the right mouse button.



Combinations and Functions with the Windows Key

Combinations	Functions
 + F1	Displays Windows Help.
 + Tab	Switches the selected button on the taskbar.
 + E	Displays Windows Explorer.
 + F	Displays the Windows Find: All Files window to find a file or folder. This is the equivalent of selecting Find and then Files or Folders from the Start menu.
 + Ctrl + F	Displays the Windows Find: Computer window where you can locate other computers. This is the equivalent of selecting Find and then Computer from the Start menu.
 + M	Minimizes all displayed windows.















Combinations	Functions
Shift +  + M	Returns all minimized windows to their previous size.
 + R	Displays the Run window. This is the equivalent of selecting Run from the Start menu.
Fn +  + Insert	Displays the Properties window. This is the equivalent of clicking the System icon in the Control Panel.

Indicators

Indicators	Functions	
Power 	Lights when the power to the computer is turned on. Flashes in System Suspend mode. Turns off when the computer is in System Hibernation mode or powered off.	
Battery 	Indicates the status of the battery attached at the rear of the computer.	
Information 	Depending on the VAIO Action Setup setting, the Information indicator lights when you have received new e-mail and/or retrieve e-mail.	
Light	On	Off
Hard disk 	Data is being read from or written to the hard drive. Do not enter System Suspend mode or turn off the computer when this indicator light is on.	The hard drive is not being accessed.

Light	On	Off
Num Lock 	The number keys in the numeric keypad are active.	The character keys in the keypad area are active.
Caps Lock 	The letters appear in uppercase as you type. The Shift key lowers the case of typed letters when Caps Lock is on.	Letters appear in lower case as you type (unless you hold down the Shift key).
Scroll Lock 	The screen scrolls differently. (Exactly how it scrolls depends on the specific application. It has no effect in many applications.)	Information moves across the display normally.

Combinations and Functions with the Fn Key

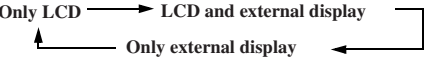
Combinations/ Feature	Functions
Fn+  (ESC) System Suspend	Puts the system into System Suspend mode, a power management state. To return the system to the active state, press any key or press the power switch on your computer.
Fn+  (F3) Speaker switch	Toggles the built-in speaker off and on.
Fn+  (F4) Speaker volume	Adjusts the built-in speaker volume. To increase volume, press Fn+F4, then  or  . To decrease volume, press Fn+F4, then  or  .
Fn+  (F5) Brightness control	Adjusts the brightness of the LCD. To increase light intensity, press Fn+F5 and then  or  . To decrease light intensity, press Fn+F5 and then  or  .
Fn+  /  (F7) Switch to the external display	Toggles through the LCD, external display (connected to the  Monitor connector on the port replicator) and both LCD and external display. 

Combinations/ Feature	Functions
Fn+  (F12) System Hibernation	Provides for the lowest level of power consumption. When you execute this command, the state of the system and state of the peripheral devices are written to the hard disk and the system power is turned off. To return the system to the original state, use the power switch to turn on power.
Fn+D Video standby	Turns off the LCD to save power. To turn the LCD back on, press any key (Windows® Me only).
Fn+B Mega-Bass switch	Toggles the mega-bass function off and on. This feature is available with headphone only.
Fn+S System Idle	Puts the system into System Idle mode, a power management state. To return the system to the active state, press any key.

 You can also carry out these functions using the Jog Dial control.

Some functions are not available until Windows launches.

Using the Touchpad

The keyboard contains a cursor-pointing device called a touchpad. You can point to, select, drag, and scroll objects on the screen using the built-in touchpad.

Touchpad

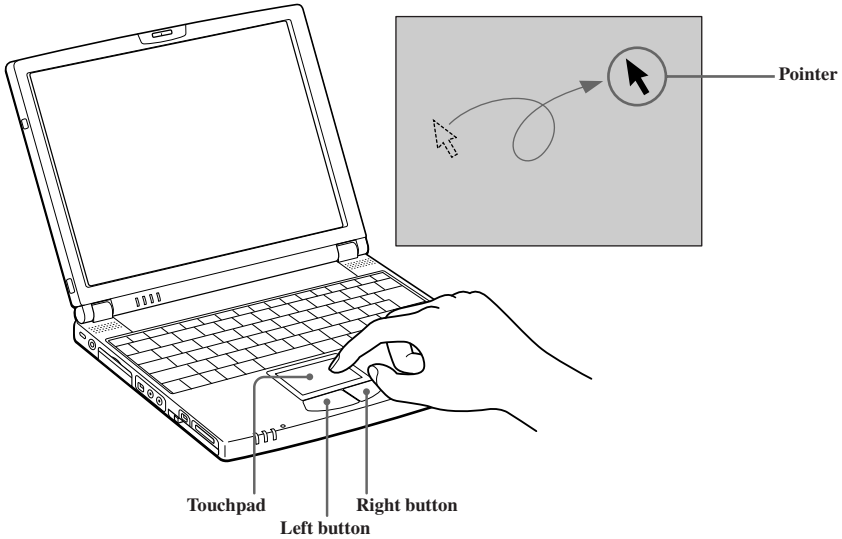

Actions	Descriptions
Point	Slide one finger on the touchpad to place the pointer on an item or object.
Click	Press the left button once.
Double-click	Press the left button twice.
Right-click	Press the right button once. In many applications, this action displays a shortcut menu of context-sensitive choices.
Drag	Slide one finger while pressing the left button.
Scroll	Move your finger along the right edge of the touchpad to scroll vertically. Move your finger along the bottom edge to scroll horizontally. (The scroll function is available only with applications that support a touchpad scroll feature.)

 See Mouse Properties for information on touchpad features, such as clicking both buttons simultaneously, adjusting touchpad speed, and Easy Launcher functions. To access Mouse Properties, press the Start button, select Settings, and then select Control Panel. Double-click the Mouse icon in the Control Panel.

Using the Floppy Disk Drive

You can connect the floppy disk drive to the  (USB) connector on your computer.



To connect the floppy disk drive

 You do not need to shut down the computer before connecting or disconnecting the floppy disk drive. Before removing the FDD, see “To remove the floppy disk drive when the computer is on” .

- ❑ Plug the USB cable from the floppy disk drive into the  (USB) connector on the computer. The VAIO logo on the disk drive should be facing up.

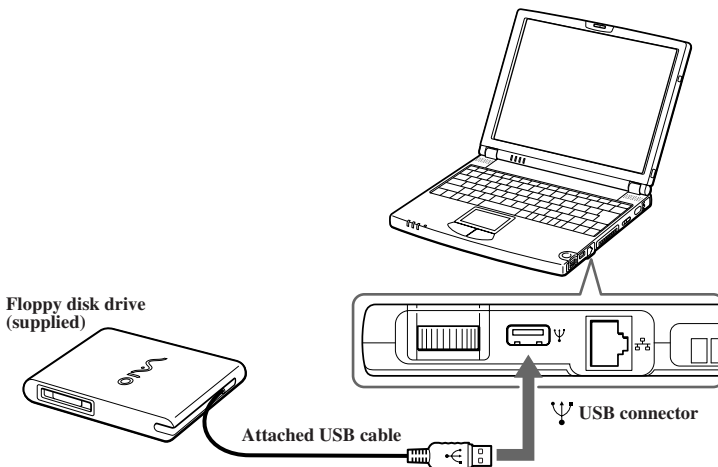
Connecting the FDD



 To use two USB devices at the same time, plug the second device into the  (original mini USBconnector) on the left side of the computer, using the supplied conversion adapter.

To boot your computer from a floppy disk you must connect the floppy disk drive to the USB port on right side of the computer as shown above.

To insert a diskette

- 1 Hold the diskette with the label side facing up.
- 2 Gently push the diskette into the drive until it clicks into place.

Inserting diskette

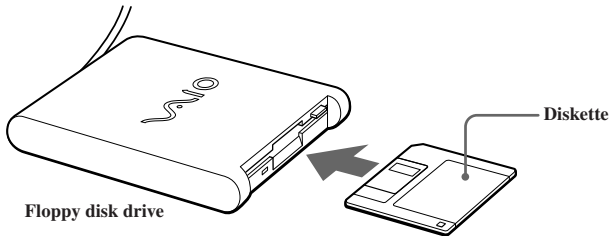

To remove a diskette

- When you finish using the diskette, wait until the LED indicator turns off and then press the Eject button to remove the diskette.

Removing diskette

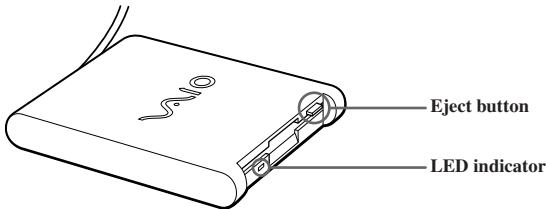

To remove the floppy disk drive when the computer is on

- 1 Double-click the Remove Hardware icon  in the task tray.
- 2 The “Unplug or Eject Hardware” dialog displays.
- 3 Select the hardware device you wish to remove by clicking it.
- 4 Click stop.

- 5 Confirm the correct device is selected in the “Stop a hardware device” dialog box.
- 6 The message, “Floppy Disk Drive can now be safely removed from the system” appears. Click OK.
- 7 Slide the release lever on the bottom of the computer in the direction of the arrow, and then unplug the floppy disk drive from the computer.

(Windows Me only) If you choose and remove the USB Disk, the internal memory stick becomes disabled.

If you have removed the USB Disk by mistake (instead of the USB floppy), take the following steps to recover it.

- 1 Open the start menu, select Settings, Control Panel, and then the System icon. The Device Manager appears.
- 2 Click the Refresh button.
- 3 In the “Stop a Hardware device” dialog box, confirm that the device can be safely removed from the system. Click OK.

To carry the floppy disk drive

Fold the floppy disk cable into the compartment on the right side.

Notes on handling diskettes

- Do not open the shutter manually and touch the surface of the diskette.
- Keep diskettes away from magnets.
- Keep diskettes away from direct sunlight and other heat sources.

Connecting the CD/DVD Drive (optional)

You can use the optional PCGA-CD51/A CD-ROM drive, or the PCGA-DVD51A DVD drive with your notebook. If you use an optional drive when your computer is running on battery power, the battery life will be shorter. The drive draws power from the computer through a PC card.

 Windows Me does not support PCGA-CDRW51.

To Connect the CD Drive

 You can connect a PCGA-CD51/A CD-ROM drive while the computer is on, unless you want to use the System and Application Recovery CDs. Turn off your computer before using the System and Application Recovery CDs.

Procedures for connecting the CD drive may vary, depending on the CD drive.

See the manual that came with your CD drive for more information on use.

(For Windows® 2000) To play an audio CD in the optional PCGA-CD51 series CD-ROM drive with your notebook, your computer's settings must be set properly. You can check the settings as follows:

- 1 Click the Start button, select Settings, and then Control Panel.
- 2 Double-click the System icon.
- 3 Click the Hardware tab and click Device Manager.
- 4 Double-click the drive you use under DVD/CD-ROM drive.
- 5 Click the Property tab and make sure the “Enable digital CD audio for this CD-ROM device” box is checked.

- 1 Remove the PC card slot protector from the PC card slot. See “Using PC Cards” on page 42 for details.
- 2 Remove the PC card from the bottom side of the CD drive.

Removing PC Card

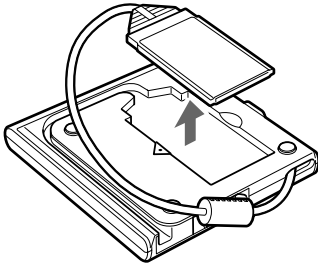

- 3 Insert the PC card into the PC card slot with the SONY logo facing up. See “Using PC Cards” on page 42 for details.

Inserting PC Card

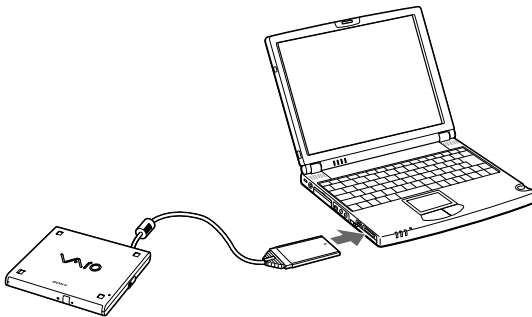

 A protective cover is attached to the lens of the CD-ROM drive at the factory. Before using the CD-ROM drive, remove the protective cover.

To Insert a Disc

- 1 Press the Eject button. The disc tray slides out.

CD-ROM Drive

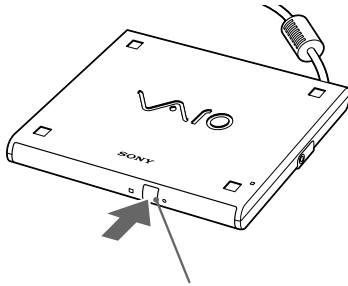

- 2 Place the disc in the tray with the label side facing up. Push the disc onto the hub until the disc clicks into place.

Inserting Disc

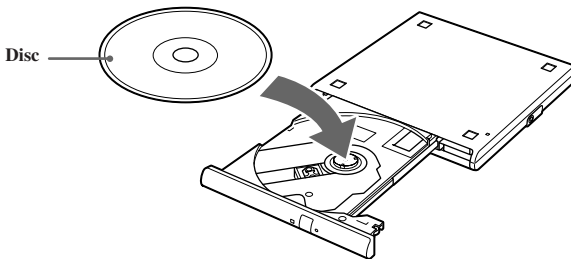

- 3 Close the tray by pushing it gently. The BUSY indicator on the drive flashes while your computer is reading data from the disc.

Flashing BUSY Indicator

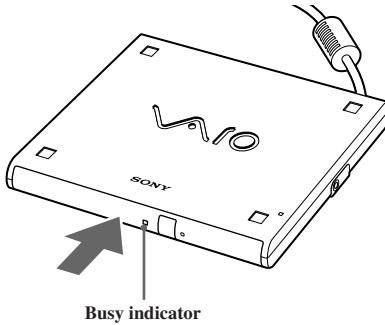

Notes on CD and DVD Media

To Remove the Drive

Remove the PC card from the computer. See “Using PC Cards” on page 42 for details.

Handling CD or DVD Media

- Do not touch the surface of the disc.
- Do not drop or bend the disc.

Cleaning CD or DVD Media

- Fingerprints and dust on the surface of a disc may cause read errors. Proper care of the disc is essential to maintain its reliability. Do not use solvents such as benzene, thinner, commercially available cleaners or anti-static spray, as they may cause damage to the disc.
- For normal cleaning, hold the disc by its edge and use a soft cloth to wipe the surface from the center out.
- If the disc is badly soiled, moisten a soft cloth with water, wring it out well, and use it to wipe the surface of the disc from the center out. Wipe off any remaining moisture with a dry soft cloth.

Using PC Cards

Your computer includes a PC card slot. PC cards allow you to connect portable external devices, such as a CD-ROM drive.

 The PC card slot can accommodate one Type I or Type II PC card. This slot is compatible with 16 bit card and Card Bus. ZV (Zoomed Video) port is not available.

Some PC cards may require that you disable idle devices when using the PC card. You can use Sony Notebook Setup to disable devices. See “Displaying the Sony Notebook Setup Screen” in the online manual *Customizing Your VAIO® Z505 SuperSlim Pro™ Notebooks* for details.

Be sure to use the most recent software driver provided by the PC card manufacturer. If an “!” mark appears on the Device Manager tab in the System Properties dialog box, remove the software driver and then reinstall it.

To insert a PC card

 You do not need to shut down the computer before inserting or removing a PC card.

- 1 Pull the PC card release button up away from the computer and push it in towards the computer.

PC Card Release Button

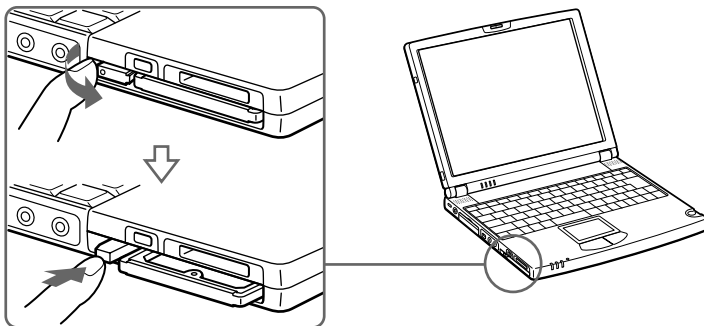

- 2 Remove the PC card slot protector.

Removing PC Card Slot Protector

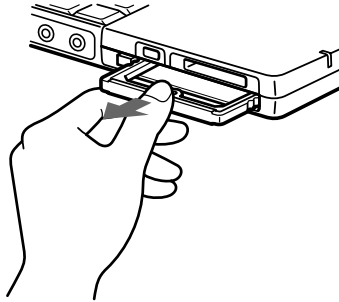

- 3 Insert the PC card into the PC card slot, front label facing up. Gently push the card into the slot until the card is fixed into the connector. The release button comes out.

Inserting PC Card

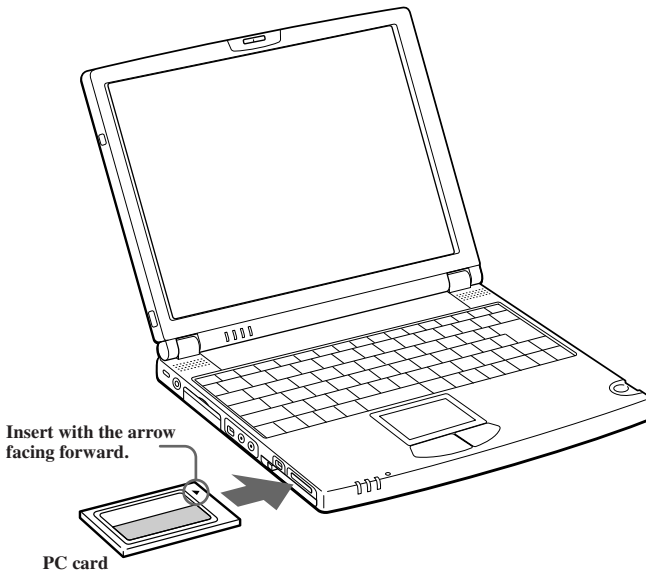

 Do not force a card into the slot. It may damage the connector pins.

If you have difficulty inserting a card, check that you are inserting the card with the correct orientation.

Do not carry your computer while touching the head of a PC card (such as a wireless LAN card), pressure or shock may damage the connector pins.

See the manual that came with your PC card for more information on its use.

To remove a PC card

 When your computer is turned on, please take the following steps to unplug this device from the computer. Otherwise, your system might crash and you might lose data that you didn't save before.

If your computer is off, you do not have to follow these instructions.

- 1 Close any applications that use the PC card, otherwise data may be lost.
- 2 Click the Unplug or Eject Hardware icon in the taskbar and select the card.
- 3 Click Stop, in the Stop a Hardware device dialog box, confirm the device to stop and click OK.
- 4 Click Close to close the Unplug or Eject Hardware window.
- 5 Pull the PC card release button up and press it in towards the computer.

Removing PC Card

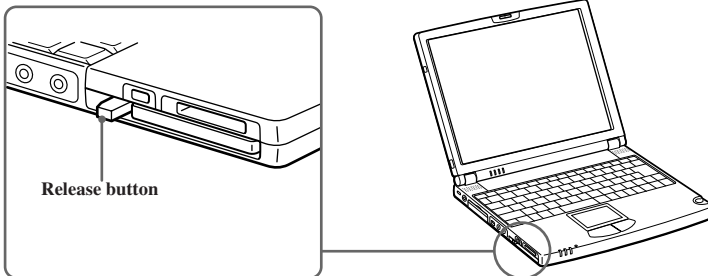

- 6 Gently grasp the card and pull it out.

7 Insert the PC card slot protector into the empty slot.

 For some PC cards, if you alternate between normal power operation and the System Suspend or System Hibernation power saving modes while the card is inserted, you may find that a device connected to your system is not recognized. Reboot your system to correct the problem.

If you choose and remove the USB Disk, the internal memory stick becomes disabled. If you have removed the USB Disk by mistake (instead of the USB floppy), take the following steps to recover it (Windows Me only).

- 1 Open the start menu, select Settings, Control Panel, and then the System icon. (If you cannot find the icon you are looking for, click the hyperlink “Display all the options of Control Panel”.) The Device Manager appears.
- 2 Click the Refresh button.
- 3 In the “Stop a Hardware device” dialog box, confirm that the device can be safely removed from the system. Click OK.

Using Smart Connect

Windows Me™

You can connect your VAIO® notebook to another VAIO computer that has the preinstalled Windows Me operating system or the Sony Smart Connect 3.0 software preinstalled. You may use an i.LINK® cable (optional) to connect the two systems and then use one computer to edit, copy, or delete files on the other computer. You can also print from a printer that is attached to either computer. Select the STD mode in Smart Connect 3.0 software to connect with another computer that has Windows Me preinstalled.

Connecting with an i.Link cable

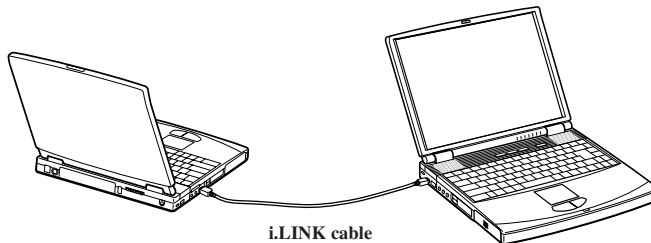

Windows 2000

The preinstalled Smart Connect software allows you to use an i.LINK® cable (optional) to connect your VAIO notebook to another VAIO computer that also has Smart Connect or preinstalled Windows Me. You can then use one computer to edit, copy or delete files on the other computer. You can also print from a printer attached to either computer.

See Smart Connect online help for more information.

 When you connect two VAIO computers, you must assign each computer a unique name. The computers can be identified by this unique name when the two computers are networked together.

 If you have previously purchased a VAIO computer or notebook that does not have the Windows Me operating system or Smart Connect 3.0 software preinstalled, consult the Sony website for support options (<http://www.sony.com/pcsupport>).

Connecting an i.LINK® device*

Your VAIO Z505 SuperSlim Pro notebook includes an **i.LINK** (IEEE1394) S400 connector, which you can use to connect to a compatible i.LINK device such as a digital video camera recorder.

To Connect a Digital Video Camera Recorder

Plug one end of an i.LINK cable into the **i.LINK** S400 connector on the left side of the computer and the other end into the DV In/Out connector on the digital video camera recorder. If your digital video camera recorder includes a **Memory Stick®** slot, you can copy images from it to your computer via a **Memory Stick** media. Copy images to the **Memory Stick** media and insert the media into the **Memory Stick** slot on your computer. For details on using **Memory Stick**, see “Using Memory Stick® Media” on page 53.

Connecting digital video camera recorder

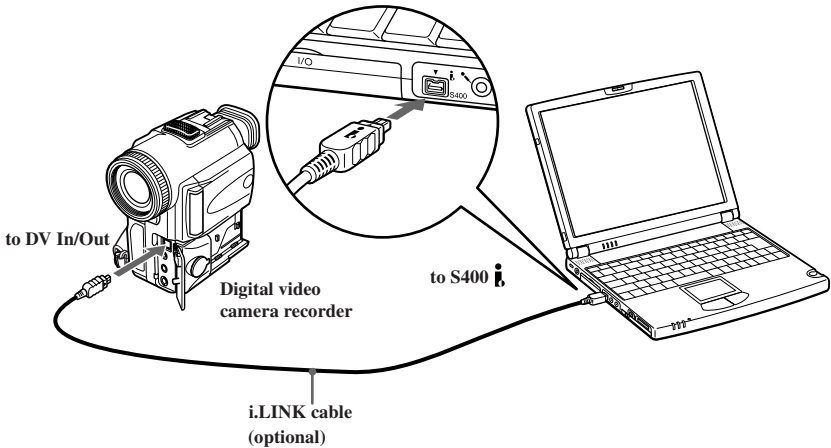

* i.LINK is a trademark of Sony used only to designate that a product contains an IEEE1394 connector. All products with an i.LINK connector may not communicate with each other.

 The Sony digital video camera recorder is pictured; your digital video camera recorder may need to be connected differently.

Only Sony digital video cameras, and connectors labeled “DV In/Out” or “i.LINK” are i.LINK-compatible.

See the manual that came with your digital video camera recorder for more information on installation and use.

The i.LINK connector does not supply power to external devices. If the external device requires power from the i.LINK connector, you cannot use the device with your computer.

The VAIO Z505 SuperSlim Pro notebook supports transfer rates up to 400 Mbps; however, the actual transfer rate is the lowest transfer rate of the external device.

The i.LINK features available may vary depending on the software applications you use. See the documentation that came with your software for more information.

See page 47 for a list of i.LINK cables compatible with your VAIO Z505 SuperSlim Pro notebook.

You can connect a digital video camera to the i.LINK connector on your notebook or the i.LINK connector on the optional port replicator. When a camera is connected to the i.LINK connector on the notebook, you should not connect any other devices to the i.LINK connector on the port replicator. When a camera is connected to the i.LINK connector on the port replicator, you should not connect any other devices to the i.LINK connector on the notebook.



i.LINK cables compatible with your VAIO Z505 SuperSlim Pro notebook include cables with the following part numbers: VMC-IL4415 (a 1.5-meter cable with a 4-pin connector at each end), VMC-IL4615 (a 1.5-meter cable with a 4-pin connector at one end and a 6-pin connector at the other), and VMC-IL4408A (a 0.8-meter cable with a 4-pin connector at each end). You can purchase these cables from your local retailer, through the Sony VAIO® Direct website (<http://vaio.sonystyle.com>) or by calling 1-888-315-7669 (toll free).

Hard Drive Partition

In order to improve the performance of your computer's DVgate™ Motion software, the hard disk drive on your computer has been formatted with two partitions, C and D.* DVgate Motion saves files to the D partition. This prevents large video captures from consuming the available space on your C partition. To maintain optimum performance of DVgate Motion, you should defragment your D partition regularly. See the DVgate Motion online help for more information.

* See "Specifications" on page 109.

VAIO Action Setup

VAIO Action Setup manages the settings for your computer's Jog Dial™ control, **Memory Stick® media**, and i.LINK® interface. An overview of some of the functions controlled by VAIO Action Setup is provided below. For more information on changing the settings using VAIO Action Setup, right-click the Jog Dial control icon  or , in the task tray and click Help Topics.

The Jog Dial™ Control

Your computer is equipped with a Jog Dial control on the right side of the unit. The Jog Dial control enables you to open an application, folder, or document from a predefined list by rotating and pressing the Jog Dial control. In addition, when you press the Jog Dial control, you can turn on your computer automatically and start the selected application or document.

Jog Dial Control

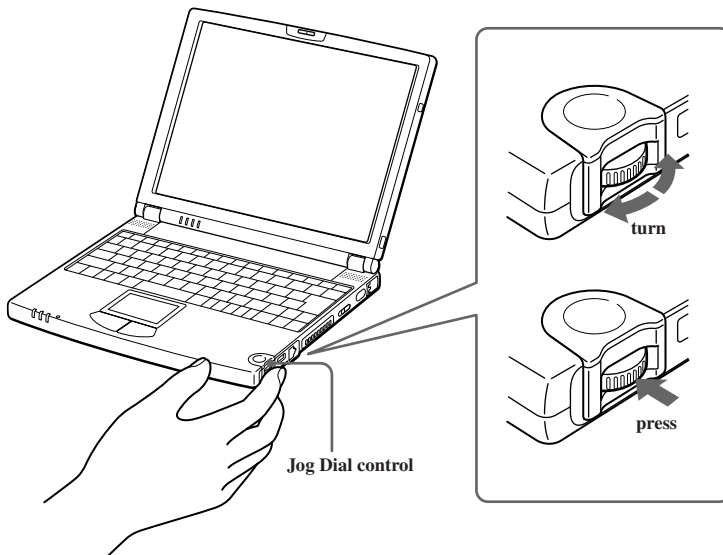

The Jog Dial control window always appears in the display. It is either in the launcher mode or in the guide mode.

Using the Jog Dial™ Control

This section explains how to use the Jog Dial control. For information on how to change the Jog Dial control's settings, right-click the Jog Dial control icon in the task tray and click Help Topics.

Launcher Mode

The Jog Dial control window is in launcher mode until a software application is launched or the Jog Dial control window becomes active. When an arrow is displayed next to an item in the Jog Dial control window, you can display a submenu of that item by selecting it and pressing the Jog Dial control button.

Using Launcher Mode

To use the Jog Dial control, click the Jog Dial control window or the Jog Dial control icon in the task tray. Alternatively, you can press the Jog Dial control while pressing the Ctrl key on the keyboard to switch to the launcher mode.

- 1 Turn the Jog Dial control to select the item you want, then press the Jog Dial control. The window switches to the guide mode, and shows the Jog Dial's function.

JOG Guide Dialog Box



- 2 Turn or press the Jog Dial control to use the desired function.
- 3 To select another item, switch to the launcher mode and repeat from step 1.

Guide Mode

The Jog Dial control window is in the guide mode when software is in use and the software window is active. Depending on the software you are using, you can select items from the displayed list using the Jog Dial control. Some Sony software applications have two modes in List View, Simple Menu and Full Menu. You can switch the mode by pressing the shift key while turning the Jog Dial control.

Using Guide Mode

The Jog Dial control window displays the Jog Dial's function.

Using the Jog Dial Control with Sony Software

If Sony software that supports the Jog Dial control is active, you can use the Jog Dial's functions that are allocated to that software. For more information on functions allocated to software, see the software applications online Help.

Using the Jog Dial Control with Other Software

If the software you are using does not support the Jog Dial control, you can still perform the following functions:

Action	Description
Maximize Window*	Press the Jog Dial control button to maximize the size of the active window. Press again to return to normal window size.
Minimize Window*	Press the Jog Dial control button to minimize the size of the active window. Press again to return to normal window size.
Finish Window*	Press the Jog Dial control button to close the active application.
Scroll*	Press the Jog Dial control button to begin scrolling within the active window.
Jog Dial Launcher	Press the Jog Dial control button to return the Jog Dial control to Jog Launcher mode.
Menu Bar	Press the Jog Dial control button, then use the Jog Dial control to scroll through the active window's toolbar.

* Some software does not support these functions.

Using a Dialog Box

When a window such as Screen Properties is active, the Dialog box is displayed in the Jog Dial window. You can select an item in the window by rotating the Jog Dial control. Pressing the Jog Dial control is the equivalent of pressing Enter.



JOG Guide dialog box



Using Memory Stick® Media

This new compact, portable, and versatile recording medium has a data capacity exceeding that of a floppy disk. The media is specially designed for exchanging and sharing digital data with compatible products. Because it is removable, the media can be used for external data storage.

Types of Memory Stick Media

Two types of **Memory Stick** media are available. The first type, **MagicGate™**  (hereafter referred to as **MG™ Memory Stick** media), is provided with copyright protection. The second type, simply referred to as **Memory Stick**  media, does not have the same copyright protection as MagicGate.

You can use both media with your notebook.

For music, which requires copyright protection, you can only use **MG Memory Stick** media with your notebook. You can also use MagicGate-compatible devices to record and playback music when they are connected to your computer.

You can store mixed data on the **Memory Stick** media. For example, you can copy an image on to **MG Memory Stick** media that already contains music.

What is MagicGate?

MagicGate is copyright protection that consists of authentication and encryption technology. Authentication technology ensures that protected content is only transferred between compliant devices and media. Protected content is recorded and transferred in an encrypted format to prevent unauthorized duplication or playback.

 Ensure that the **MG Memory Stick** media has the MG mark .

To Insert a Memory Stick Media

1 Insert with the arrow facing upward and toward the Memory Stick slot.

 Inserting the media in the wrong direction may damage the connector pins.

2 Carefully slide the Memory Stick in until it clicks in place.

Inserting Memory Stick

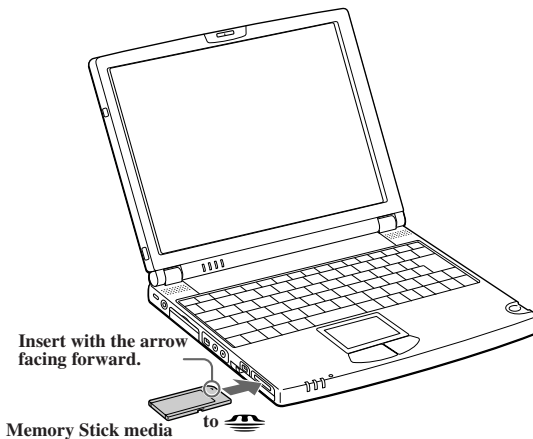

To view the contents of Memory Stick media

You can also see the contents by clicking the Removeable Disk (S:) icon.

If you cannot see the Removable Disk (S:) under My Computer on your desktop:

- 1 Click Start, point to Settings and then Control Panel.
- 2 Click System. The System Properties window appears.

 If you cannot find System, open the Control Panel window and select Display Control Panel options.

- 3 Select the the Device Manager tab.

Warning: When copying data between Memory Stick media with different memory capacity, use the drag and drop method to copy data. Do not use the Copy Disk function of Windows. The Copy Disk function will result in the loss of the installed memory.

To Remove a Memory Stick Media

Make sure the access light is off. Push the media in toward the computer. When the media ejects, pull it out. When removing the **Memory Stick** media, be careful as it may eject completely from the slot.

Notes on using Memory Stick media:

- ❑ When the media's erasure prevention switch is set to LOCK, data cannot be recorded or erased.
- ❑ Before using **Memory Stick** media, you should back up important data.
- ❑ Wait a minimum of 10 seconds after the media finishes reading or writing data before removing it. If the media is removed prematurely, a blue screen with an error message appears, prompting you to continue or exit. Re-insert the media into the slot and press Enter to continue. This allows the media to finish reading or writing data.
- ❑ You can enjoy video clips that you have recorded with **Memory Stick**-compatible video camera recorders.
- ❑ The media slot can accommodate one media at a time.
- ❑ To copy images from a digital video camera via **Memory Stick** media, see “Connecting an i.LINK® device” on page 47.
- ❑ To copy images from a digital still camera via the **Memory Stick** media, see “To connect a digital still camera” in the online manual “Customizing Your VAIO® Z505 SuperSlim Pro™ Notebook.”

- ❑ Only MagicGate™ Memory Stick media can be used with copyright protected data like music.
- ❑ Do not remove a media or turn off the power while the access light is on.
- ❑ Do not use the media in locations that are subject to static electricity or electrical noise.
- ❑ Do not touch the media connector with your finger or metallic objects.
- ❑ Do not attach labels other than the supplied label to a media.
- ❑ Do not bend, drop, or apply strong shock to the media.
- ❑ Do not disassemble or modify the media.
- ❑ Do not allow the media to get wet.
- ❑ Do not use or store the media in a location that is subject to:
 - ❑ Extremely high temperatures, such as in a car parked in the sun
 - ❑ Direct sunlight
 - ❑ High humidity or places with corrosive substances

To prolong the life of the media, use the supplied storage case. See the instructions that come with your media for more information on use.

Using Power Saving Modes

When you use a battery as the source of power for your computer, you can take advantage of power management settings to conserve battery life. In addition to the normal operating mode, which allows you to turn off specific devices, your computer has three distinct power saving modes: System Idle, System Suspend, and System Hibernation. When using battery power, you should be aware that the computer automatically enters System Hibernation mode when the remaining battery charge drops to approximately 10%, regardless of the power management setting you select.

 If your battery level falls to less than 10%, you should either attach the AC adapter to recharge the battery or shut down your computer and insert a fully charged battery.

Normal Mode

This is the normal state of your computer when it is in use. The green power indicator light is on in this mode. To save power, you can turn off a specific device such as the LCD or the hard disk.

 For details, see “Controlling Power Management” in the online manual *Customizing Your VAIO® Z505 SuperSlim Pro™ Notebook*.

System Idle Mode

This mode is convenient if you do not need to use your computer for a brief period. The hard disk and video display enter a low power state, and the CPU clock and processor stop. The power indicator light is tan in this mode.

To activate System Idle Mode

Press Fn+S. You can also use the PowerPanel utility to enter System Idle mode.

To return to normal Mode

Press any key.

System Suspend Mode

The computer saves the current state of the system in RAM and switches off power to the CPU. The tan power indicator light flashes in this mode.

To activate System Suspend Mode

Press Fn+Esc. You can also use the PowerPanel utility to enter System Suspend mode.

To return to normal Mode

Press any key.

System Hibernation Mode

The state of the system is saved on the hard drive and power is turned off. The power indicator light is off in this mode.

To activate System Hibernation mode

To activate System Hibernation mode, press the key combination Fn+F12.

 (Windows 2000) The “Save to Disk Manager” screen appears, and then the computer enters System Hibernation mode.

 Do not move the notebook until its power indicator light turns off.

To return to normal Mode

Turn on the computer by sliding the power switch forward. The computer returns to its previous state.

 When returning from System Hibernation mode, the system status stored on the hard disk is erased and the computer starts normally if you slide the power switch forward and hold for more than four seconds.

- ❑ Time to return to normal mode:
System Idle requires less time than System Suspend, and System Suspend requires less time than System Hibernation.
- ❑ Power consumption:

System Idle uses more power than System Suspend, and System Suspend uses more power than System Hibernation.

If you enable Wake on LAN, please be aware that your standby power saving mode will be switched to the System Idle mode from the System Suspend mode.

Connecting Peripheral Devices

You can add functionality to your computer by connecting any of these peripherals:

- ❑ Phone line (page 60)
- ❑ Port replicator (page 63)
 - ❑ External display (page 66)
 - ❑ Printer (page 70)
- ❑ CD-ROM drive (page 38)
- ❑ i.LINK device (page 63)
- ❑ Universal Serial Bus (USB) device (page 71)

Connecting a Phone Line (optional)

You need to connect a phone line to take advantage of online services, the Internet, and Sony Customer Support.

 In order to register your Sony VAIO® Z505 SuperSlim Pro™ notebook, register your software online, and use Sony Customer Support, you must connect to a phone line.

- 1 Open the phone line jack cover. The cover opens only to a 45-degree angle.

 Do not plug the phone cable into the Ethernet port  as this may damage your notebook.

Phone Line Jack Cover

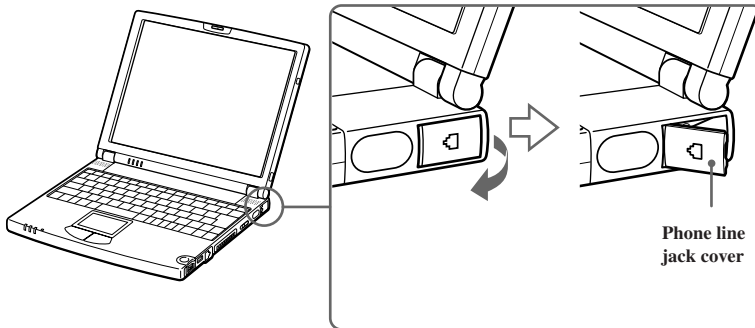

- 2 Plug one end of the phone cable (optional) into the jack on the inside of the phone line jack cover. Make sure you insert the phone cable from the rear of the computer and that the modular jack clicks into place.

- 3 Plug the other end into the wall jack.

Plugging Phone Line into Phone Line Jack

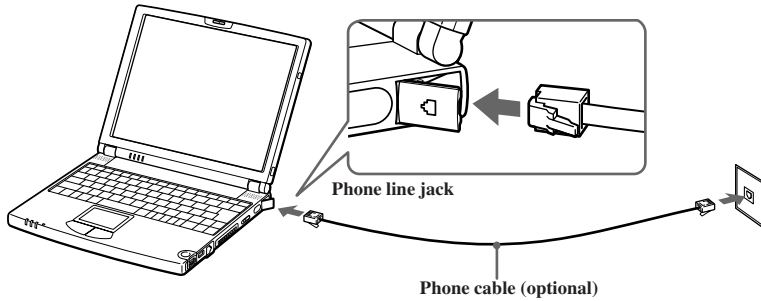



 Your computer does not work with party lines, cannot be connected to a coin-operated telephone, and may not work with multiple phone lines or a private branch exchange (PBX). Some of these connections might result in excess electrical current and could cause a malfunction in the internal modem.

Connecting to the Local Area Network (LAN)

You can connect your computer to 10BASE-T and 100BASE-TX-type networks. For the detailed settings and devices needed to connect to the network, please ask your network administrator.

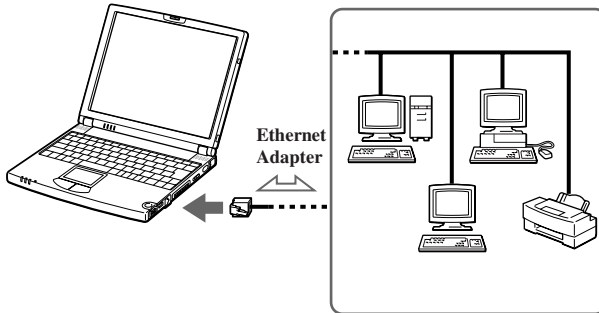
Connecting to LAN



Warning: Only connect 10BASE-T and 100BASE-TX cables to the  (Ethernet network) port. Do not connect any other type of network cable or any telephone line. Connecting cables other than those listed above may result in an electric current overload and could cause a malfunction, excessive heat, or fire in the connector. To connect the unit to the network, contact your network administrator.





If you enable Wake on LAN, please be aware that your standby power saving mode will be switched to the System Idle mode from the System Suspend mode.

Connecting the i.LINK® Port Replicator

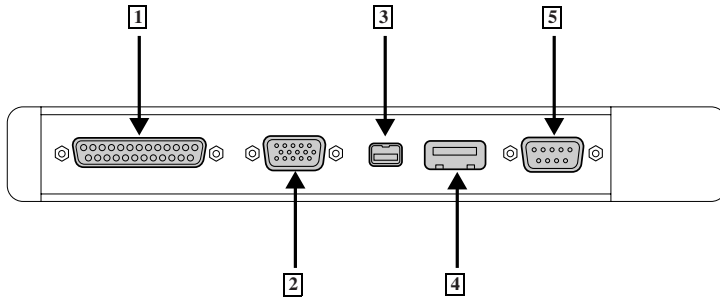
You can use the PCGA-UPR5 i.LINK port replicator (supplied) to connect peripheral devices such as a printer or external display. The port replicator has five ports, including an i.LINK port.

Port Replicator



- | | |
|---|--|
| 1 |  Printer |
| 2 |  Monitor |
| 3 |  i.LINK® device |
| 4 |  USB device |
| 5 |  Serial |

 You cannot use the optional PCGA-PR5 port replicator with your computer.

To Attach the Port Replicator

- 1 Turn off the computer.
- 2 Open the port replicator connector cover on the left side of the computer.

Port Replicator Connector

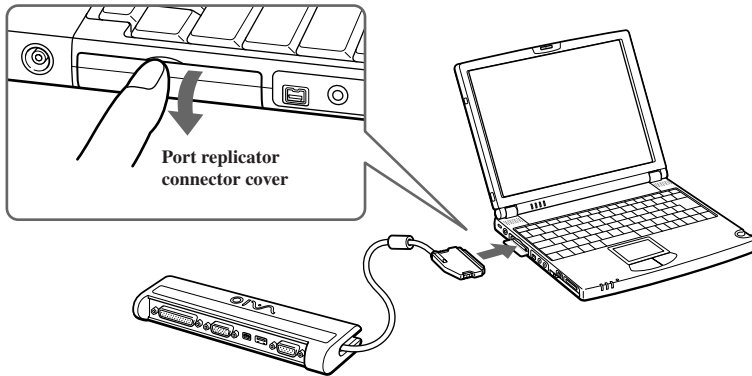

- 3 Plug the port replicator cable into the port replicator connector on the computer.

To Remove the Port Replicator

- 1 Turn off the computer.
- 2 Press both sides of the port replicator cable connector and unplug the cable from the computer.

Attaching Computer to Port Replicator

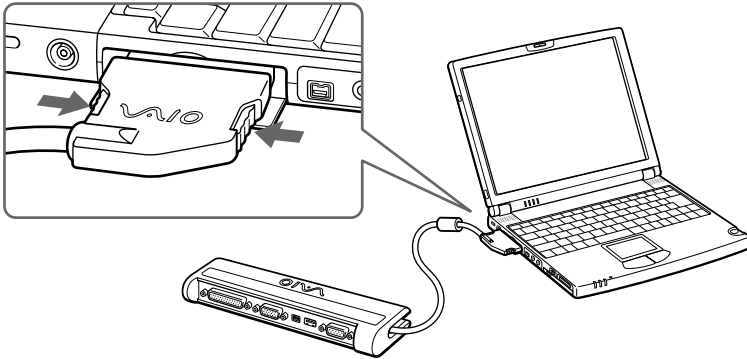

- 3 Fold the port replicator cable into the compartment on the side of the port replicator.

Connecting AC Adapter to Port Replicator

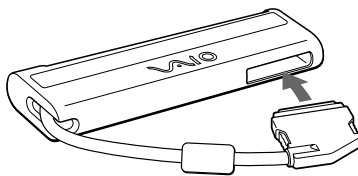

Connecting an External Display

You can connect your notebook to a computer display (monitor) or projector.

To Connect a Monitor

Use the I/O port replicator connector on the left side of the computer. Plug the display adapter (optional) into this connector. If necessary, plug one end of the display's power cord into the display, and the other end into an AC outlet.

Connecting Monitor

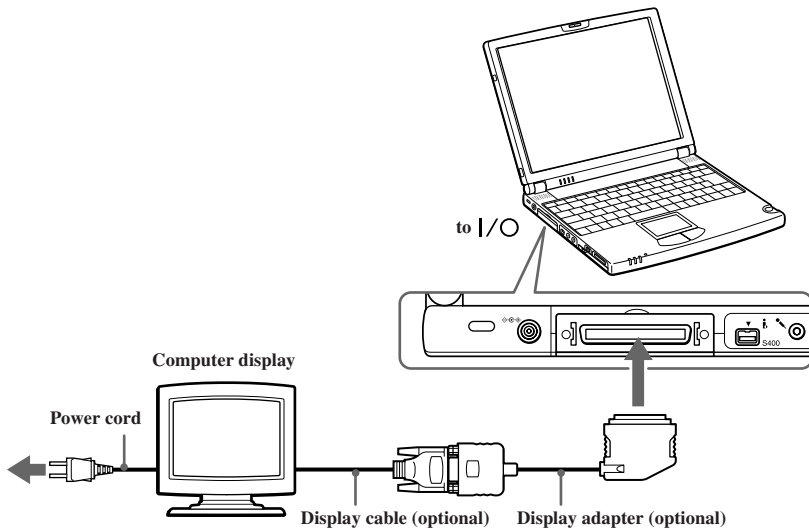

 See the manual that came with your computer display (monitor) for more information on installation and use.

To Connect a Projector

You can use a projector, such as the Sony LCD Projector, as an external display.

Connecting Projector

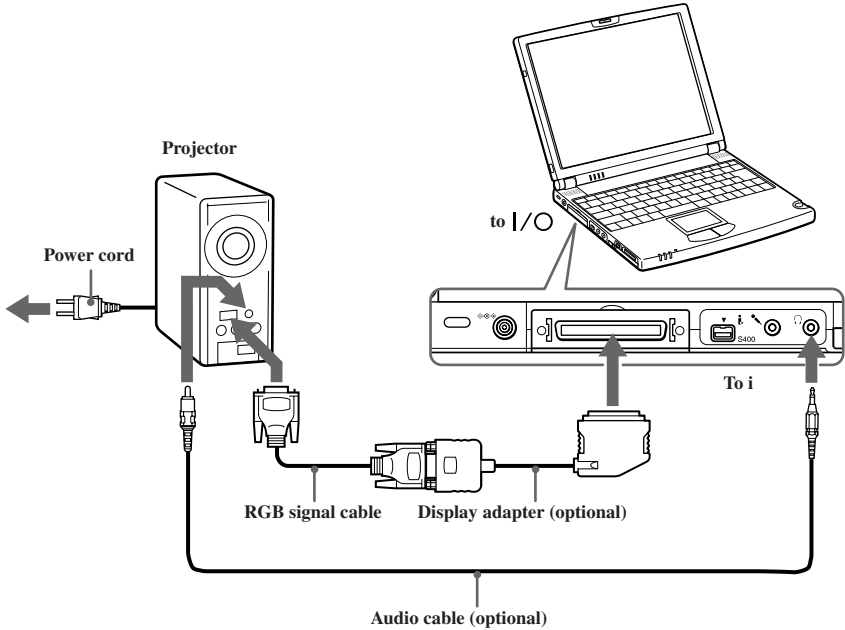

 See the manual that came with your projector for more information on installation and use.

To Remove the Display Adapter

Press both sides of the display adapter connector and unplug it from the computer.

To Select a Display

When you connect an external display to your computer, you can press Fn+F7 to toggle the output between the Liquid Crystal Display (LCD), the external monitor, or both devices.

 See "Selecting the Display Mode" in the online manual *Customizing Your VAIO® Z505 SuperSlim Pro™ Notebook* for more information.

Connecting an External Display

You can use the port replicator to connect an external display to your notebook computer. For example, you can use the computer with any of the following:

- ❑ Computer display (monitor) (“To Connect a Computer Display (Monitor)” on page 68)
- ❑ Projector (“To Connect a Projector” on page 69)

To Connect a Computer Display (Monitor)

- ❑ Use the  symbol on the port replicator to locate the Monitor connector. Plug the display cable into this connector.
- ❑ If necessary, plug one end of the display power cord into the display, and the other end into an AC outlet.

Connecting monitor

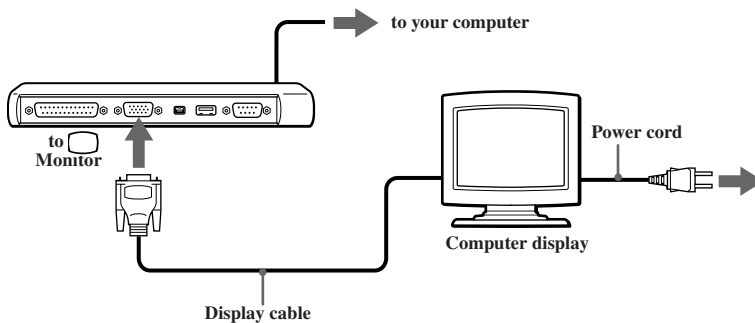



 See the manual that came with your computer (monitor) display for more information on installation and use.

The optional display adapter PCGA-DA5 allows you to connect a display directly to the port replicator connector, eliminating the need for the port replicator.

To Connect a Projector

You can use a projector as an external display, such as the Sony LCD Projector.

- 1 Use the  symbol to locate the Monitor connector. Plug the RGB signal cable into this connector.
- 2 Use the  symbol to locate the Headphone connector. Plug the audio cable into this connector.

Connecting projector

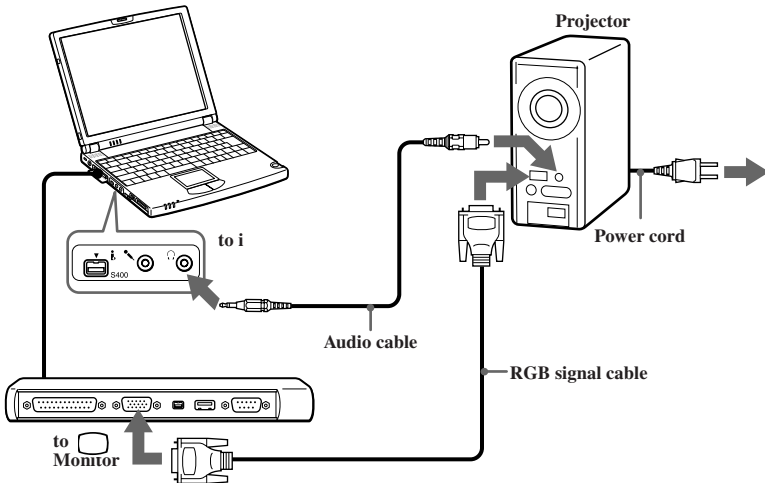

 See the manual that came with your projector for more information on installation and use.

To Select a Display

When you connect an external display to the monitor connector, you can press Fn+F7 to toggle the output between the Liquid Crystal Display (LCD), the external monitor, or both devices. See “Selecting the Display Mode” in the online manual *Customizing Your VAIO® Z505 SuperSlim Pro™ Notebook* for more information.

Connecting a Printer

You can use the port replicator to connect a compatible printer or other parallel port device to your computer.

- ✎ Turn off the computer before connecting peripherals. In normal use, you should turn on the peripherals before turning on the computer. You can connect i.LINK devices while the computer is on.

Connect the AC adapter only after connecting all cables.

To Connect a Printer

- ❑ Use the  symbol to locate the Printer connector on the port replicator. Plug the printer cable (supplied with the printer) into this connector.

Connecting Printer

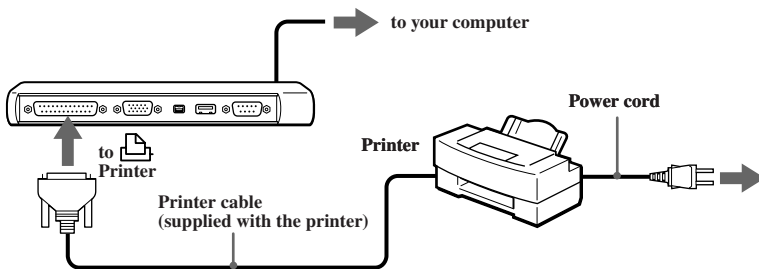

- ❑ You can connect a compatible USB printer to your computer. Use the  symbol to locate the USB port on your computer and printer. Plug the USB printer cable (optional) into the USB connector

- ✎ See the manual that came with your printer for more information on installation and use.

Before using the printer, you may need to change the Printer setting in the Sony Notebook Setup software. See "Displaying the Sony Notebook Setup Screen" in the online manual *Customizing Your VAIO® Z505 SuperSlim Pro™ Notebook*.

Connecting a Universal Serial Bus (USB) Device

You can connect a USB device, such as a USB mouse, to your computer.

To Connect a USB Device

Use the Ψ symbol to locate the USB connector on the right side of the computer. Plug one end of the USB cable into this port and the other end into the USB mouse.

Connecting USB Device

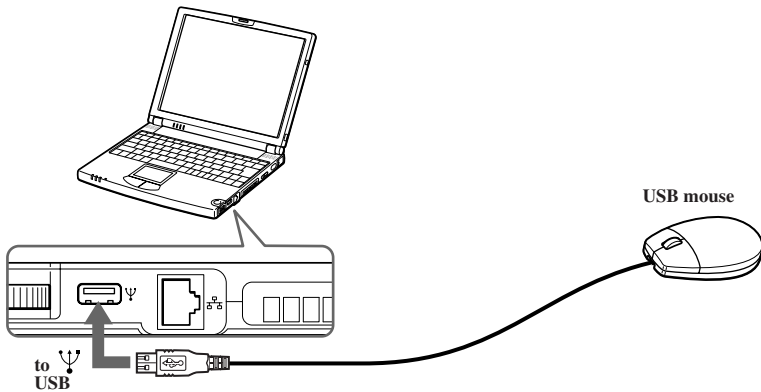

To Connect a Second USB Device.

When you wish to use another USB device, such as a floppy disk drive, at the same time, connect the second USB device to the (original mini USB) connector by attaching the supplied conversion adapter.

Attaching Second USB Device

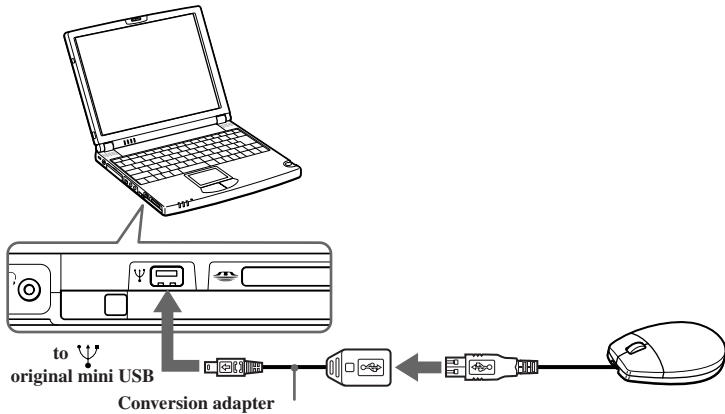

 You can use the optional Sony USB mouse (PCGA-UMS1 series) with this computer. Plug the USB mouse into the USB connector. You do not need to turn off your computer.

See the manual that came with your USB device for more information on installation and use.

 Connecting the port replicator will disable the original mini USB adapter.

Adding Memory

In the future you may want to install memory modules to expand the functionality of your computer. You can increase memory to 192 MB on the PCG-Z505LE and the PCG-Z505LEK and you can increase memory to 256 MB on the PCG-Z505LS and PCG-Z505LSK. The PCG-Z505LE/PCG-Z505LEK has 64 MB of memory and the PCG-Z505LS/PCG-Z505LSK has 128 MB of memory. For memory upgrades, use only PC-100 SDRAM SO-DIMM (gold lead contacts).

Sony recommends memory upgrades be performed by an authorized Sony Service Center or Sony authorized agent. To find the nearest center or agent, see <http://www.sony.com/pcsupport>.

Make sure you observe the proper safety precautions when you install a memory module in your computer. See the bulleted list below. Be careful when adding memory. Mistakes when installing or removing a memory module may cause a malfunction.

- ❑ The procedures described below assume familiarity with the general terminology associated with personal computers and with the safety practices and regulatory compliance required for using and modifying electronic equipment.
- ❑ Disconnect the system from its power source and from any telecommunications links, networks, or modems before you open the system or follow any of the procedures described below. Failure to do so may result in personal injury or equipment damage.
- ❑ Electrostatic discharge (ESD) can damage disk drives and other components. Perform the procedures described below only at an ESD workstation. If such a station is not available, do not work in a carpeted area, and do not handle materials that produce or hold static electricity (cellophane wrappers, for example). Ground yourself by maintaining contact with an unpainted metal portion of the chassis while performing the procedure.
- ❑ Do not open the memory module package until you are ready to install the module. The package protects the module from ESD.
- ❑ Use the special bag for preventing ESD or use aluminum foil when you store the memory module.

To Install a Memory Module

- 1 Shut down your computer and disconnect all peripheral devices, such as your printer.
- 2 Unplug the computer and remove the battery packs.
- 3 Wait until the computer cools down. Then unscrew the six screws with the ● mark on the bottom of your computer.

Screws

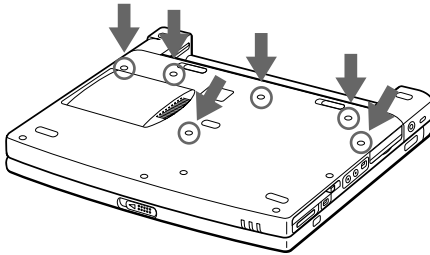

- 4 Slide the LCD lock lever and lift the cover. Slide the keyboard toward the LCD display, then lift it away slightly.

Lifting the Keyboard

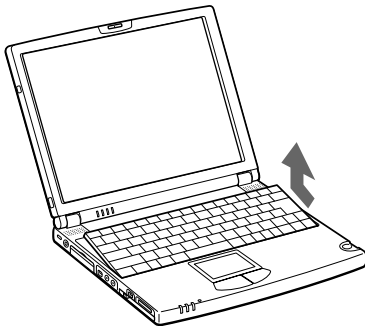

- 5 Lift the keyboard from the LCD display side, then gently turn it over on the touchpad space. Be careful not to detach the cable when lifting the keyboard.

Turning the Keyboard

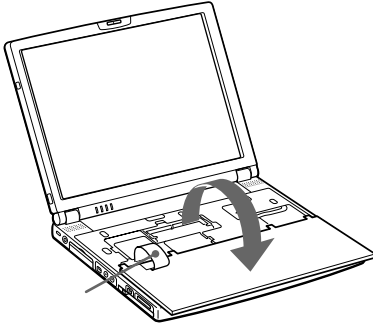

- 6 You must remove the existing memory module. Follow the instructions in “To Remove a Memory Module” on page 77.
- 7 Remove the memory module from its packaging.
- 8 Install the memory module. Be careful not to touch the other components on the motherboard.

Installing the Memory Module

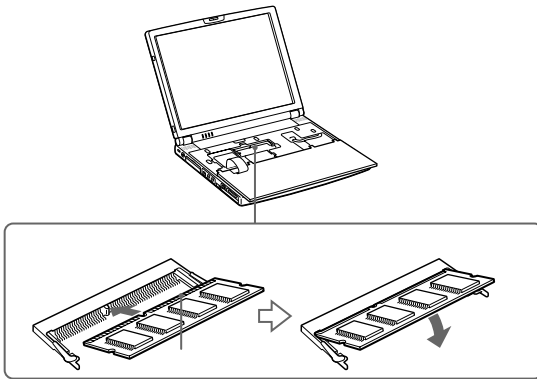

- 9 Gently replace the keyboard, then press it into your computer. Be careful not to detach the cable when lifting the keyboard.

Replacing the Keyboard

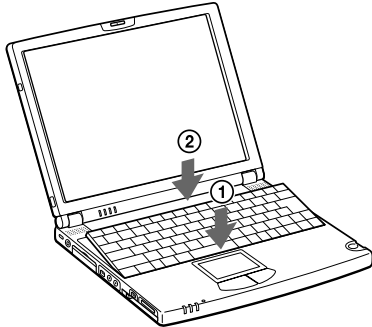

 If you cannot reset the keyboard correctly, check that the heat sink has not been moved into the area where the keyboard must be placed.

- 10 Close the computer cover, then tighten the screws on the bottom of the computer.

To Remove a Memory Module

- 1 Follow steps 1 to 5 of “To install a memory module.”
- 2 Touch a metal object (such as the connector panel on the back of your computer) to discharge static electricity.
- 3 Remove the memory module.
- 4 Follow steps 8 and 9 of “To install a memory module.”

About the Software on Your Computer

Your VAIO® notebook is ready to help you work, play, learn, and communicate as soon as you turn it on. This section gives you an overview of the activities you can perform with your software titles. For support information, see “For Answers to Your Software Questions” on page 13.

Adobe Acrobat Reader®

Adobe Systems Inc.

Acrobat Reader software allows you to view, navigate, and print electronic documents in Adobe Portable Document Format (PDF), an open file format that is intended to preserve the fidelity of documents created on all major computer platforms.

Adobe PhotoDeluxe® Home Edition

Adobe Systems Inc.

Create amazing photo effects with Adobe PhotoDeluxe. Without learning complex software, you can enhance, restore, and be creative with your photos. Includes built-in guided activities, stock photos, clip art and templates to assist you.

Adobe Premiere® LE

Adobe Systems Inc.

Adobe Premiere LE offers an interface and editing tool for producing movies for video, multimedia, or the Web. View source clips and edited footage simultaneously on the monitor window. Create video clips up to three hours long with complete audio-video synchronization.

ArcSoft® PhotoPrinter™ 2000 Pro

ArcSoft, Inc.

ArcSoft PhotoPrinter 2000 Pro is an easy-to-use, advanced printing program that lets you quickly lay out multiple images in multiple sizes on a single sheet of paper. PhotoPrinter Pro offers a wide selection of templates including landscape, portrait, free style, mixed sizes, custom templates and more. The application includes enhancement tools and special effects for improving photos while giving you the ability to add text to any image.

DVgate™

Sony Electronics Inc.

Connect a digital video camera recorder to the i.LINK® connector and capture your own video clips and still images. You can edit the clips from your video, add others, and combine clips into new movie segments. You can also save your images in a variety of popular file formats.

McAfee® VirusScan®

Network Associates, Inc.

Protect your computer from viruses. VirusScan can detect viruses from floppy disks, Internet downloads, e-mail attachments, intranets, shared files, CD-ROMs, and online services.

Media Bar™

Sony Electronics Inc.

Media Bar software is your all-in-one solution for audio/video playback. Media Bar software handles all common computer multimedia formats and controls selected Sony devices. In addition to audio/video library cataloging and playlist management, Media Bar software includes digital video quality control and effects features. Media Bar software seamlessly integrates a variety of new media formats with an easy-to-use software interface.

Microsoft® Internet Explorer

Microsoft Corporation

Internet Explorer delivers the web the way you want it. It is safe, easy to use, and you can personalize how you access the web. Outlook Express and other tools in Internet Explorer also help you have a great experience when you are on the web.

Microsoft® Word 2000

Microsoft Corporation

Microsoft Word 2000 makes it easy to create common Web, e-mail, and print documents for use around the world. It embraces HTML as a first-class file format and extends this software's ease-of-use to the Web and e-mail. Word 2000 also extends that ease-of-use to international users, making it simple to create multilingual documents.

MovieShaker™

Sony Electronics Inc.

Sony's original MovieShaker software creates personal movies that have transitions, background music and text. Just import your video clips and "shake" with the click of a mouse. Your personal movies are easy to create and fun to share with family and friends.

Netscape Communicator®

Netscape Communications

Netscape Communicator is an all-in-one Internet tool that makes it easy to browse the web, send Internet e-mail, chat, read newsgroups and compose great web documents.

OpenMG™ Jukebox

Sony Electronics Inc.

OpenMG Jukebox software enables you to import digital audio files by downloading audio files from Electronic Music Distribution (EMD) services over digital networks, such as the Internet. You can record audio CDs onto your hard drive in a variety of formats.

PictureGear™

Sony Electronics Inc.

This image management software displays images from your hard drive, a Sony Digital Still Camera, or a Sony Mavica® Camera. The images appear in a convenient light-table format, so that you can easily view the contents of an entire folder.

Quicken® 2000 Basic

Intuit, Inc.

Quicken is a fast, easy way to organize your finances. Quicken works just like your checkbook, so it is easy to learn and use. Quicken manages all your finances, bank accounts, credit cards, investments, and loans. You can even pay your bills online.

Smart Capture

Sony Electronics Inc.

Smart Capture is a fun new way to send multimedia messages via e-mail. Smart Capture manages the i.LINK connection between your computer and a Sony Digital Handycam® camcorder that supports the i.LINK interface. It allows you to capture compressed video or still images that you can save or share via e-mail. A smart solution to computer, digital audio/video and network convergence.

Sound Forge® (Windows 2000 only)

Sonic Foundry

Sound Forge XP allows you to put powerful audio processing tools and effects to work on your notebook. Simply cut, copy, and paste your way to striking multimedia files for use in everything from Web pages to desktop presentations.

Smart Connect (Windows 2000 only)

Sony Electronics Inc.

Smart Connect allows you to use an i.LINK® cable (optional) to connect your VAIO computer to another VAIO computer that supports Smart Connect. You can then use one computer to copy, delete, and edit files on the other computer. You can also print from a printer attached to either computer.

VAIO Action Setup

Sony Electronics Inc.

VAIO Action Setup manages the settings for your computer's Shortcut keys and i.LINK interface.

VAIO Support Agent

Sony Electronics, Inc

VAIO Support Agent provides immediate, interactive, on-line support.

About Your Recovery CDs

Application Recovery CD(s)

Sony Electronics

This program allows you to reinstall individual applications and device drivers. Use it to restore corrupted or erased files.

System Recovery CD(s)

Sony Electronics

This program allows you to restore the software titles that shipped with your computer if they become corrupted or are erased accidentally. It can be used only to restore the hard disk of the Sony computer you purchased.

Supplementary Information

Recovering Microsoft® Word 2000

If you recover your operating system using the System Recovery CD, Microsoft Word 2000 will not be recovered. Use the supplied Word 2000 CD-ROM to recover this application.

Software Information

MovieShaker™

This application can be used to create fun and innovative movies without any knowledge of film editing. In a few simple steps, motion pictures can be combined with special effects, still images (pictures), and music files and then saved in a format most computers can play.

Main window

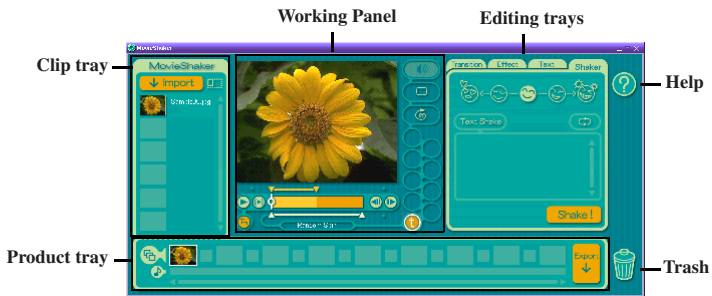

Importing Images and Sound Clips

- 1 Click .
- 2 Find the file you want to add.
- 3 Select the file.
- 4 Click Open. The file is added to the Clip tray.

 Importing files over 75 seconds in length may cause MovieShaker to stop responding.

Create a Movie using Shaker

After adding clip(s) to the Clip tray, you can create a short movie using the Shaker feature. Shaker randomly select clips from the Clip tray to create a 30-second scene.

- 1 Click the Shake tab.
- 2 Select a mood by clicking a face in the Shaker tray.

Shaker Tray



- 3 Click **Shake !**. A thirty second scene is automatically generated and saved to the Product tray.
- 4 To preview, switch the Work Panel to Product tray mode and press play.

 Scenes created with Shaker begin with black frame and after processing are placed in the first available slot on the Product tray. Limit the number of scenes placed on the Product tray to 10 or less. MovieShaker may stop responding if too many scenes are placed on the Product tray.

Editing Clips and Scenes

You can edit your movie by adding effects and text, adjusting the color and contrast, and modifying the length of clips.

Working Panel

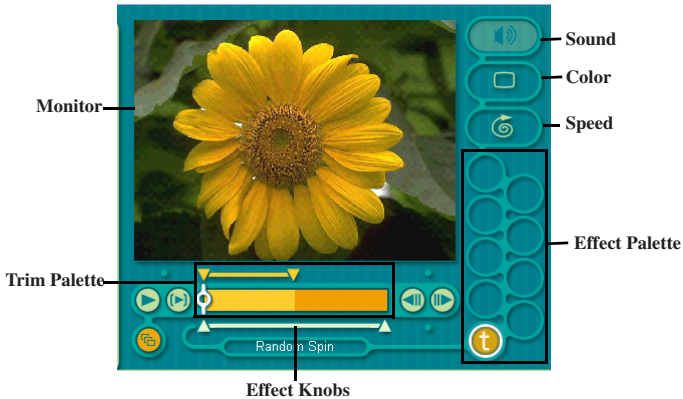

Adding effects to a scene or a clip:

- 1 Double-click the clip or scene to move it to the Working Panel.
- 2 Select the Effects tab from the Editing tray.
- 3 Drag and drop the Effect you want to add from the Effects tray to the Effects palette on the Working Panel.

 To preview an Effect, click on the clip in the Working panel monitor. Your clip displays with the new effect on the Effect tray monitor.

- 4 See help for instructions on adjusting effect duration and replaying clips/scenes.

Saving a Movie

- 1 Verify that the clip(s) you want to save is on the Product tray. See Help for more details on saving movies.
- 2 Click Export.
- 3 Select the format in which you want the document to be saved.

- 4 Click Next.
- 5 Locate the folder to which you want the file saved.
- 6 Name the file.
- 7 Click Save.

! Exporting movies may take a long time to complete—Saving movies as DV (Digital Video) takes the longest and Quick-Save is the fastest. MovieShaker can play video files up to 65 MB in length.

 For DV playback and smooth video playback, we recommend the following resolution/refresh rates: 1024 x 768/75 Hz or lower.

PictureGear™

PictureGear is a digital image management application that allows you to see all the images stored in any directory on your computer. Thumbnail views provide quick reminders of your pictures. Brighten, contrast, enhance, resize, crop, and color-correct your pictures. Create panoramic views, animations, screen savers, wallpaper, still pictures from MPEG, and even html photo albums.

Managing Your Pictures

Use the collection feature to manage your pictures.

- 1 Click the Folder tab and browse to locate your pictures.
- 2 Select the pictures you want to have in a collection.
- 3 From Collection menu, select Create New Collection.
- 4 Enter a name for the collection and then click OK.

Creating a Photo Album

- 1 Select the pictures you want to use to make an album.
- 2 From the Utilities menu, select Album Maker.
- 3 Choose the type of Album you want and click OK.
- 4 Now add more pictures, frames, text, and effects.
- 5 When you are finished, select Create Album in File menu or click the Create Album icon on the toolbar.
- 6 Designate the folder where you want to save the Album.
- 7 Enter the Target Album name, select Thumbnails and click OK.
- 8 The new album can be viewed using most internet browsers.

Using Panorama Maker

Panorama Maker stitches a group of still images into a 360 degree panoramic picture. The source images should be the same size and overlap 20%.

How to stitch a panoramic picture:

- 1 Gather the source images into the same folder or collection.
- 2 Select the images you want to use.

 We recommend 12 landscaped or 16 portrait pictures.

- 3 From the Utilities menu select Panorama Maker.
- 4 Select the correct lens and click OK. (If 35mm lens is selected, the prompt does not appear; to select a different lens, click the lens icon.)
- 5 Click the panoramic icon, near the bottom of the window.
- 6 Click Full Stitch.

Making Still Images and Panoramic from MPEG

- 1 Select the MPEG file.
- 2 From the Movie/Sound menu, select Scene break down.
- 3 Then select Movie Stitch, to create a panoramic picture.

For Answers to Your Software Questions

Acrobat Reader®, Adobe PhotoDeluxe® Home Edition, Adobe Premiere® LE (Adobe Systems Incorporated)

Web site	http://www.adobe.com/
phone	206-628-2746 (fee-based support)
fax	206-628-5737
e-mail	techdocs@adobe.com
hours	M-F, 6 AM-5 PM PT

America Online® (America Online)

Web site	http://www.aol.com
phone	800-827-3338
hours	7 days a week, 24 hours a day

CompuServe® 2000 (CompuServe, Inc.)

Web site	http://www.compuserve.com
phone	800-848-8990

EarthLink Network TotalAccess® (EarthLink Network, Inc)

Web site	http://help.earthlink.net/techsupport/
phone	800-395-8410
e-mail	support@earthlink.net
hours	7 days a week, 24 hours a day

McAfee® VirusScan® (Network Associates, Inc.)

Web site	http://support.mcafee.com
phone	408-988-3832
e-mail	cybr@nai.com
hours	M-F 9AM-5PM Central Time

Netscape Communicator® (Netscape Communications Corporation)

Web site	http://www.netscape.com/
phone	888-4SONYPC (888-476-6972)*
hours	7 days a week, 24 hours a day

* Support from 1-888-4SONYPC is free of charge for 90 days after the original date of purchase.

PhotoPrinter™ 2000 Pro (ArcSoft, Inc.)

Web site(s)	http://www.arcsoft.com http://www.photoisland.com
phone	510-440-9901
fax	510-440-1270
e-mail	techsupport@arcsoft.com
hours	M-F, 8:30 AM-5:30 PM PT

Prodigy Internet® (Prodigy Communications Corporation)

Web site	http://www.prodigy.com
phone	800-213-0992
hours	7 AM - 3 AM ET

Quicken® 2000 (Intuit Inc.)

Web site	http://www.intuit.com/support
phone	900-555-4688
hours	7 days a week, 24 hours a day

RealProducer® G2 (RealNetworks, Inc.)

Web site	http://www.realnetworks.com/
phone	206-674-2681
fax	206-674-3586
e-mail	http://service.real.com (online form)
hours	M-F, 8 AM-5 PM PT

Internet Explorer (Microsoft Corporation)

Web site	http://www.microsoft.com/support/
phone	888-4SONYPC (888-476-6972)*
hours	7 days a week, 24 hours a day

* Support from 1-888-4SONYPC is free of charge for 90 days after the original date of purchase.

Windows 2000 Operating System, Internet Explorer (Microsoft Corporation)

Web site	http://www.microsoft.com/support/
phone	888-4SONYPC (888-476-6972)*
hours	7 days a week, 24 hours a day

* Support from 1-888-4SONYPC is free of charge for 90 days after the original date of purchase.

Sony Service Center

For the Sony Service Center nearest you, call 1-888-4SONYPC (1-888-476-6972) or find Sony Customer Service on the Web at <http://www.sony.com/pcsupport>.

Using the System and Application Recovery CDs

The following sections describe how to use the System Recovery and Application Recovery utilities. You need to connect the optional PCGA-CD51/A CD-ROM drive or the PCGA-DVD51/A DVD drive to use the System and Application Recovery CDs. (Windows Me does not support PCGA-CDRW51).

Using the System Recovery CD(s)

You can reinstall software titles that shipped with your computer if they are corrupted or accidentally erased. You may not need to recover the entire contents of your hard drive. If you experience a problem with your computer, reinstalling an individual device driver or software title may correct the problem. Use the Application Recovery CDs to reinstall individual applications or device drivers. See “Using the Application Recovery CD(s)” on page 94.

-  Please read the manuals of the optional disc drive carefully before you connect it for recovery purposes.
- If you use PCGA-DVD51/A DVD-ROM drive, do not connect the AC adapter supplied with the drive.

The System Recovery CD contains a backup copy of all the software originally installed on your hard disk drive. **It can be used only to recover the hard disk of the notebook computer you purchased.**

The System Recovery utility gives you two options:

- ❑ **Full Restore without Format** — Restores all the software titles that originally came with your computer without formatting the hard disk.

 If you recover your operating system using the System Recovery CD, Microsoft Word 2000 will not be recovered. Use the supplied Word 2000 CD-ROM to recover this application.

- ❑ **Full Restore with Format** — Formats the hard disk drive and then restores all the original software.

! **If you choose the Full Restore with Format option, your hard disk will be formatted, which removes all the information on the hard disk drive. You will lose any software you have installed and any other files you have created since you started to use your computer. This means you will have to reinstall any applications that were not included with the computer when you purchased it. If you choose the Full Restore without Format option, you may need to reinstall applications that were not included with the computer when you purchased it. If you have any questions on using the System Recovery CD, contact Sony Customer Support.**

To use the System Recovery CD(s)

 The optional PCGA-CD51/A CD-ROM drive or the PCGA-DVD51A DVD drive must be connected to the computer to use the System Recovery CD.

You need to complete the Windows registration process when you use the System Recovery CD. Make sure you have the product ID number located on the cover of your Microsoft Windows Getting Started manual. You will need this number to complete the recovery process.

- 1 Insert the Sony System Recovery CD in the CD-ROM drive.
- 2 Shut down your computer as described in “Shutting Down Your Computer” on page 28.
- 3 Wait four seconds and turn on your computer.

- 4 Click OK to signify you have read and accept the Microsoft End-User License Agreement.
- 5 When the System Recovery menu appears, follow the on-screen instructions to complete the recovery process.

 Your system may include one or two System Recovery CDs. If you have two System Recovery CDs, insert the first CD to run the System Recovery program. You are prompted to insert the second CD once the information from the first CD has been installed.

The recovery process takes 30 to 60 minutes to complete. After recovering your system using the SRCD, you may be prompted to insert your ARCD after restarting Windows. Insert the ARCD to complete recovery of your system.

If your computer does not start from the System Recovery CD

- 1 Slide the power switch forward and hold it for more than four seconds to turn off the computer.
- 2 Turn on the computer and press the F2 key when the Sony logo appears. The BIOS setup menu screen appears.
- 3 Press the arrow keys to select the Exit menu.
- 4 Press the arrow keys to select Get Default Values and then press the Enter key. The message “Load default configuration now?” appears.
- 5 Check that Yes is selected, then press the Enter key.
- 6 Press the arrow keys to select Exit (Save Changes) and then press the Enter key. The message “Save configuration changes and exit now?” appears.
- 7 Check that Yes is selected, then press the Enter key. The computer restarts from the Recovery CD.

 After recovering your system using the System Recovery CD, you may be prompted to insert your Application Recovery CD at the first boot. Insert the Application Recovery CD to complete full recovery of your system.

Using the Application Recovery CD(s)

The Application Recovery CDs allow you to reinstall individual applications and device drivers if they are corrupted or accidentally erased. Reinstalling an individual device driver or software title may correct a problem you are experiencing with your computer, and you may not need to recover the entire contents of your hard drive. If you do need to reinstall all the software titles that shipped with your computer, use the System Recovery CD. See “Using the System Recovery CD(s)” on page 91.

 You must be in Windows to run the Application Recovery CDs.

Some applications on the Application Recovery CDs must be decompressed before the installation process begins. Your screen does not change while the files are decompressed. The time to decompress an application varies and may be as long as 30 minutes.

To use the Application Recovery CD(s)

- 1 Turn on your computer. If your computer is already on, close all applications.
- 2 When the Windows desktop appears, insert the first Sony Application Recovery CD in the CD-ROM drive. The Application Recovery utility loads automatically.
- 3 When the Application Recovery menu appears, follow the on-screen instructions to complete the recovery process.

 Your system may include one or two Application Recovery CDs. If you have two Application Recovery CDs, insert the first CD to run the Application Recovery program. You may be prompted to insert the second CD, depending on the application you wish to restore.

Troubleshooting

This section describes how to solve common problems you may encounter when using your notebook. Many problems have simple solutions, so try these suggestions before you contact Sony PC Support (<http://www.sony.com/pcsupport>).

Troubleshooting your notebook

(Windows Me only) When starting your notebook for the first time, the VAIO InitManager dialog box will appear. Please select “OK” to begin initial setup. If you do not execute the initial setup, you cannot use part of VAIO original hardware functions such as Jog Dial, Power Management tool, scroll function of touchpad, and keyboard shortcut key function combined with the Fn key.

My notebook does not start

- Check that the notebook is plugged into a power source and that it is turned on. Check that the power indicator on the front panel of the notebook indicates that the power is on.
- Check that the battery packs are inserted properly and that they are charged.
- Make sure there is no diskette in the floppy disk drive.
- Confirm that the power cord and all cables are connected firmly, as described in “Connecting Peripheral Devices” on page 59.
- If you plugged the notebook into a power strip or UPS, make sure the power strip or UPS is turned on and working.
- If you are using an external display, check that it is plugged into a power source and turned on. Check that the brightness and contrast controls are adjusted correctly. See the manual that came with your display for details.
- Moisture condensation may have occurred. Do not use the notebook for at least one hour and then turn on the notebook.
- Take the battery pack off the notebook, unplug the power cord and plug it again, then turn on the power.

My notebook starts, but my system doesn't start properly

- ❑ When the internal backup battery is low on power, it may not start your system properly. The message “Press <F1> to resume, <F2> to setup” appears at the bottom of the screen. Follow these steps:
 - 1 Press F2. The BIOS Setup menu appears.
 - 2 Set the date (month/day/year). Press Enter.
 - 3 Press ↓ to select System Time, then set the time (hour: minute: second). Press Enter.
 - 4 Press → to select Exit, then press ↓ to select Get Default Values. The message “Load default configuration now?” appears.
 - 5 Select Yes and press Enter.
 - 6 Select Exit (Save Changes), and then press Enter. The message “Save Configuration changes and exit now?” appears.
 - 7 Select Yes, and then press Enter. The notebook restarts.

My notebook starts, but the message “Operating system not found” appears and Windows does not start

- ❑ Make sure there is no diskette in the floppy disk drive (non-bootable).
- ❑ If a non-bootable diskette is in the drive, follow these steps:
 - 1 Turn off the notebook, and then remove the diskette.
 - 2 Restart the notebook and confirm that Windows starts properly.
- ❑ If Windows still does not start, follow the steps below to initialize the BIOS:
 - 1 Remove any diskette from the floppy disk drive.
 - 2 Remove any peripheral devices connected to the notebook.
 - 3 Turn off the notebook and then turn it on.
 - 4 Press the F2 key when the Sony logo appears. The BIOS setup menu screen appears.
 - 5 Press the directional arrow keys to select the Exit menu.
 - 6 Press the arrow keys to select “Get Default Values” and then press Enter. The message “Load default configuration now?” appears.

- 7 Select Yes, then press Enter.
- 8 Use the directional arrow keys to select “Exit” (Save Changes), and then press Enter. The message “Save configuration changes and exit now?” appears.
- 9 Select Yes, then press Enter. The notebook restarts.

If your notebook continues to display the message “Operating system not found”, and Windows does not start, contact Sony Customer Support.

My notebook stops responding or does not shut down

It is best to shut down your notebook using the Shut Down command on the Windows Start menu. Using other methods, including those listed here, may result in loss of unsaved data.

- Try restarting the notebook. On the Windows taskbar, click the Start button, click Shut Down, and then click Restart.
- If you cannot restart as described in the preceding step, you can restart the notebook by pressing Ctrl+Alt+Delete.
- If the previous step does not work, press and hold the power button for at least four seconds. This turns off the power.
- If your notebook stops responding while playing a CD or DVD, stop the CD/DVD, and restart the notebook by pressing Ctrl+Alt+Delete.
- Unplug the notebook from the AC adapter and remove the battery pack from your notebook.

 Pressing Ctrl+Alt+Delete or turning off the notebook with the power switch may result in data loss in files that are currently open.

My notebook does not enter the power saving mode I selected. (Windows Me only)

- Click Start, point to Program, point to Accessories, point to System Tools, and then click System Information.
The Help and Support window appears.
- Click System Configuration Utility under the Tools menu.

- ❑ Click the Advanced button on the General tab, and Confirm the following information:
 - 1 Enable Deep Sleep is selected with a checkmark.
 - 2 The message “Standby function is enabled” is displayed. If the message reads “Standby function is disabled”, click the Enable button.
 - 3 The message “Hibernation feature is enabled” is displayed. If the message reads “Hibernation feature is disabled”, click the Enable button.
 - 4 Click OK and restart your notebook.

My system enters System Idle mode when System Suspend mode has been selected

- ❑ If you are connecting an optical disc drive with a PC card, disconnect it by stopping the PC card. Use the Sony Notebook Setup utility to disable devices that you are not currently using. See “To remove a PC card” on page 44 for more information.
- ❑ Make sure the PC Card is compatible with your notebook’s Windows® operating system.

 (Windows 2000 only) When the notebook enters and returns from a power saving mode after removing the optical drive, the message "Unsafe Removal of Device" may appear and the device name is shown listed as "Secondary IDE Channel. Click OK.

The Power Management setting is not responding

Your notebook’s operating system may become unstable if a lower power state, such as system hibernation is initiated and then changed before the notebook completely enters the lower power state. To restore the notebook to its normal operating stability:

- ❑ Close all open applications.
- ❑ Push and hold the power button for four seconds or longer to shut down the notebook.

The sound of my notebook’s fan is too loud

Use the PowerPanel utility to change the Thermal Control Strategy setting to Quiet. This setting slows down the CPU speed. See PowerPanel Help for more information.

Troubleshooting the LCD screen

My LCD screen is blank

- Check that the notebook is plugged into a power source and that it is turned on.
- Check that the power indicator on the notebook is on.
- Check that the battery pack(s) is inserted properly and that they are charged.
- The notebook may be in LCD (Video) Standby mode. Press any key to activate the screen.
- The display mode may be set to external display mode. Press and hold the Fn key while pressing F7 several times.

My LCD screen continues to show the previous screen. (Windows Me only)

Press the Windows key and D key twice to refresh the screen.

The image on my connected external display is not centered or sized properly

Use the controls on your external display to adjust the image. See the manual that came with your display for more information.

I want to change the video resolution of my display

You can use independent controls to change the video resolution of your display.

- Click Start, point to Settings, point to Control Panel, and then click the Display icon.
The Display Properties dialog box appears.
- Click on the Settings tab.
- Move the Screen Area slider to change your video resolution.

Troubleshooting the mouse and touchpad

My mouse does not work

- If you are using an external mouse, check that the mouse is plugged into the mouse connector. See “Connecting a Universal Serial Bus (USB) Device” on page 71 for details.

- ❑ If you connected an external mouse while your notebook is on, you must restart your notebook.
- ❑ If you are using an optional Sony USB mouse PCGA-UMS1, check that the mouse is plugged into the USB connector.

My touchpad does not work properly

- ❑ You may have disabled the touchpad without a mouse being connected to the notebook. You must restart the notebook to make the touchpad work again.
- ❑ If your touchpad is interpreting a single tap as a double-click, you must adjust the button assignments. Follow these steps:
 - 1 Click Start, point to Control Panel, and then click on the Mouse icon.
 - 2 Change the button assignments in the Mouse Properties dialog box. (One of the buttons is assigned to the double-click action.)

The pointer does not move (while using the Touchpad or Mouse)

- ❑ Click the Start button on the Windows taskbar, and select Shut Down to display the Shut Down Windows dialog box, then press Enter.
- ❑ If you cannot turn off your notebook as described in the step above, press Ctrl+Alt+Delete to restart the notebook.
- ❑ If you cannot restart your notebook as described in the step above, press and hold the power button for more than four seconds to turn off the notebook.
- ❑ If the pointer does not move while playing a disc, press Ctrl+Alt+Delete to stop playback and restart the notebook.

Troubleshooting drives, PC cards and peripheral devices

I inserted a compatible device into the multipurpose drive bay, but the icon does not appear in the My Computer window

- ❑ The device has not been recognized. Put the notebook into System Idle mode by pressing the Fn and S keys and then resume.
- ❑ If the device is still not recognized or does not appear in the My Computer window, remove and reinsert it.

My floppy disk drive can not write to a diskette

- If the diskette is write-protected, disable the write-protect feature or use a diskette that is not write-protected.
- Check that the diskette is properly inserted into the floppy disk drive.

My floppy disk drive icon doesn't appear even though it is connected

- Click Start, point to Settings, point to Control panel, and then click System. The System Properties dialog box appears.
- Click the Device Manager tab.
- Double-click Floppy Disk Controller and then click Standard Floppy Disk Controller.
- Click Delete. The Confirmation window will appear.
- Verify that Delete From All Settings is selected and press OK.
- Click Update in the System Properties window.
- Double click Disk Drive and confirm that GENERIC NEC FLOPPY DISK is shown.

My CD or DVD drive is not playing my CD or DVD properly

- Make sure the optical drive is inserted correctly into the multipurpose drive bay.
- Make sure the label of the disc is facing up.
- If the disc requires software, make sure the software is installed according to the manufacturer's instructions.
- A dirty or damaged disc may cause the notebook to stop responding while it tries to read the disc. If necessary, restart the notebook, remove the disc, and then check it for dirt or damage.
- If you see video but can not hear audio, check all of the following:
 - Check that your DVD-ROM drive does not have the mute setting enabled.
 - Check the volume setting in the audio mixer.

- ❑ If you are using external speakers, check the volume settings, and then check the connections between your external speakers and the notebook.
- ❑ Click Start >Control Panel > System > Device Manager. Check that the correct drivers are installed properly.
- ❑ Do not use adhesive labels to identify the CD. The label may come off while the disc is in use in the optical drive and cause the drive to malfunction.
- ❑ If a region code warning appears when you try to use your DVD-ROM drive, it may be that the DVD you are trying to play is incompatible with the DVD-ROM drive. Check the region code listing on the DVD packaging.
- ❑ Moisture condensation may have occurred. Leave the notebook idle for at least 1 hour with the notebook turned on.

My CD or DVD drive tray does not open

- ❑ Make sure the notebook is turned on.
- ❑ Press the Eject button on the DVD-ROM drive.
- ❑ If the Eject button does not work, you can open the tray by inserting a sharp, pointed object into the hole to the right of the Eject button.

I cannot use digital video (DV) devices. The message “DV equipment seems to be disconnected or turned off” appears.

- ❑ Check that the DV device is turned on and that the cables are properly connected.
- ❑ If you are using multiple i.LINK devices, the combination of the connected devices may cause unstable operation. In this case, turn off your notebook and all connected devices. Disconnect the devices that are not in use. Check the connections for each device, then restart your notebook.

The i.LINK-compatible devices connected to the Mini Docking Station do not work

- ❑ Use the i.LINK connector that is located on your notebook.
- ❑ If the message “There are no Digital Video devices connected to this computer, or the power is off” appears, unplug the i.LINK cable and try plugging it in again.

There are white squares on the display of my digital video device while I am recording movie images from my notebook to the digital video device

If the port replicator is attached to your notebook, follow these steps:

(For Windows Me™)

- 1 Click Start, point to Settings, point to Control Panel, and then click the System icon.
The System Properties dialog box appears.
- 2 Click the Device Manager tab. Double-click Network Adapter and then select “Klsi USB-Ethernet Device Adapter.”
- 3 Right-click Property (this only appears if the port replicator is attached).
- 4 Click the Overall tab and then click the “Impossible to use in this hardware profile” box.

(For Windows 2000)

- 1 Click Start, point to Settings, point to Control Panel, and then click the System icon.
The System Properties dialog box appears.
- 2 Click the Hardware tab and then click the Device Manager button.
- 3 Double-click Network Adapter, right-click “Klsi USB-Ethernet Device Adapter,” and then select Disabled.

My PC card is not working

- Make sure the PC card is compatible with Microsoft® Windows®.
- Use the Sony Notebook Setup utility to disable devices you are not currently using.
- If you are using two PC cards, use the Sony Notebook Setup utility to disable the devices you are not currently using.

Troubleshooting software

My software program stops responding or crashes

Contact the software publisher or designated provider for technical support. See the “About Software” section of this manual.

When I click an application icon, the message “You must insert the application CD into your CD-ROM (DVD-ROM) drive” appears and the software does not start

- ❑ Some titles require specific files that are located on the application CD. Insert the disc and try starting the program again.
- ❑ Make sure you place the CD in the tray with the label side facing up.

I hear background “noise” while using Windows Media Player to play my music CDs

Sony suggests using the preinstalled Media Bar software to play audio CDs.

I can not use the DVgate software

If your notebook is using the Ultimate Battery Life profile for its power saving mode, you cannot use DVgate or Smart Connect software. Please select another profile.

My voice-related software does not work properly

Disable echo function of the microphone by taking the following steps:

- 1 Click Start, point to Settings, and then point to Control Panel.
 - 2 Click Yamaha DS-XG.
 - 3 Click the Echo tab and remove the checkmark. Click OK.
- ❑ Contact the software publisher or designated provider for technical support

Troubleshooting the modem

My modem does not work

- ❑ Check that the phone line is plugged into the line jack. See “Connecting a Phone Line (optional)” on page 60 for details.
- ❑ Check that the phone line is working. You can check the line by plugging in an ordinary phone and listening for a dial tone.
- ❑ Check that the phone number the program is dialing is correct.
- ❑ Check that the software you are using is compatible with the notebook’s modem. (All preinstalled Sony programs are compatible.)

My modem connection is slow

Your notebook is equipped with a 56K/V.90 compatible modem. Many factors may influence modem connection speed, including telephone line noise or compatibility with telephone equipment (such as fax machines or other modems). If you think your modem is not connecting properly to other PC-based modems, fax machines, or your Internet Service Provider, check the following:

- ❑ Have your phone company check that your phone line is free from any line noise.
- ❑ If your problem is fax-related, check that there are no problems with the fax machine you are calling and that it is compatible with fax modems.
- ❑ If you are having a problem connecting with your Internet Service Provider, check that the ISP is not experiencing technical problems.
- ❑ If you have a second phone line available, try connecting the modem to that line.

Troubleshooting audio

My speakers have no sound

- ❑ If the built-in speakers are turned off, press Fn+F3 to turn on the speakers. You can also turn on the speakers using the Jog Dial control.
- ❑ If the speaker volume is turned to the minimum, press Fn+F4, and then press **↑** or **→** to increase the volume or you can use the Jog Dial control to control the volume.
- ❑ If nothing is displayed when you press Fn+F3 or Fn+F4.

- 1 Double click System in Control Panel.
 - 2 Set the sound device to enable in Device Manager.
- ❑ If your notebook is powered by batteries, check that the battery packs are inserted properly and that they are charged.
 - ❑ If you are using an application that has its own volume control, check that the volume is turned up.
 - ❑ Check the volume controls in Windows.®
 - ❑ If you connect external speakers, check that the speakers are properly connected and the volume is turned up. If the speakers have a mute button, make sure it is off. If the speakers are powered by batteries, check that the batteries are inserted properly and that they are charged.
 - ❑ If you have connected an audio cable to the Headphone connector, disconnect the cable.

My microphone does not work

If you are using an external microphone, check that the microphone is plugged into the Microphone connector.

Troubleshooting the printer

I cannot print

- ❑ The default setting for the printer port mode is correct for most printers. If you cannot print, try changing the printer port mode. In Sony Notebook Setup, select the Printer tab. If the printer port mode is set to ECP, change it to bi-directional. If the printer port mode is set to bi-directional, change it to ECP. See “Displaying the Sony Notebook Setup Screen” in the *Customizing Your Notebook* manual for details on using Sony Notebook Setup.
- ❑ Your connected printer may not function after the computer resumes from a power saving mode. If this occurs, follow these steps to reset the printer connection:
 - ❑ Right-click the My Computer icon on the desktop, and then select Properties.
 - ❑ Click the Device Manager tab.
 - ❑ Select Refresh, and then click OK. The printer should function properly.

Getting Help

Sony provides several support options for your Sony computer. When you have questions about your computer and the preinstalled software, check these sources for answers, in the following sequence:

1 ***VAIO® Notebook User Guide***

The User Guide (this manual) contains information on how to get the most from your computer, find help, and solve common problems. It also contains product specifications.

2 ***Customizing Your VAIO® Notebook***

The electronic document contains additional information on customizing your computer. You can access this guide from the Windows Start menu by selecting Programs and then VAIO User Manual.

3 ***Manuals and online help files that may accompany your preinstalled software***

Most of the manuals for preinstalled software are located on your hard disk drive as online help files. You can access the online help files from the Help menu in the specific application. A printed manual is available for some applications.

4 ***VAIO Support Agent***

VAIO Support Agent can be accessed from the Windows desktop. Using advanced diagnostic technology, Sony's VAIO Support Agent runs scheduled protections of your applications, network settings, and other important software settings. When your software is protected, you can use VAIO Support Agent to repair software problems by restoring your software to any of the previously protected states.

5 ***Sony PC Support***

Provides instant access to information on commonly encountered problems. Enter a description of your problem and the Knowledge Database searches for the corresponding solutions online. You can access the Sony PC Support at: <http://www.sony.com/pcsupport>

6 ***Sony Fax-on-Demand***

This service provides you with answers to commonly asked questions. You can use this automated service to request a list of available topics and then select the topics that you want to receive. To contact the Sony fax-on-demand service, call 1-888-4SONYPC (1-888-476-6972). (Requires a fax machine or your fax software.)

7 ***Calling Sony Customer Support***

You can call and speak with a Sony Customer Support Representative without using your computer by calling 1-888-4SONYPC (1-888-476-6972). Software support is available free of charge for 90 days after the original date of purchase.

Specifications

Model	PCG-Z505LE/PCG-Z505LEK	PCG-Z505LS/PCG-Z505LSK
Processor	Mobile Intel® Pentium® III processor 650 MHz* featuring Intel® SpeedStep™ technology†	Mobile Intel® Pentium® III processor 750 MHz* featuring Intel® SpeedStep™ technology†
Hard Disk Drive C/D Partition (Approx.)	12 GB‡ (40% and 60%)	20 GB‡ (40% and 60%)
Standard RAM	64 MB SDRAM,** expandable to 192 MB††	128 MB SDRAM,** expandable to 256 MB††
LCD Screen	12.1" XGA TFT	
L2 Cache Memory	256 KB (on CPU)	256 KB (on CPU)
MPEG	MPEG1 Digital Video supports full-screen playback	
Graphics	ATI Rage Graphics Chip with 8 MB Video RAM and 3D accelerator	
Sound Capabilities	16-bit CD-quality stereo sound	
Diskette Drive	External USB 3.5" 1.44 MB	
Modem	V.90/K56flex compatible modem‡‡	
Infrared	Supports 4 mbps, 1.1 mbps, and 115 kbps IrDA Standard	
Expansion Capabilities	One PCMCIA type II Card Card Bus support	
Built-in Capabilities	Microphone Stereo speakers Touchpad	
Telecommunication Capabilities	Data/fax send/receive	

Model	PCG-Z505LE/PCG-Z505LEK	PCG-Z505LS/PCG-Z505LSK
Connection Capabilities on Z505 SuperSlim Pro	Phone line (RJ-11) i.LINK® port replicator i.LINK (IEEE1394) 3 USB ports (1 original mini-USB port; 1 located on Port Replicator) 10Base-T/100Base-T Ethernet interface Microphone In DC In Headphone Memory Stick™	
Connection Capabilities on i.LINK Port Replicator	i.LINK Printer Serial USB VGA monitor	
Supplied Accessories	USB floppy disk drive USB conversion adapter Rechargeable battery AC adapter and power cord i.LINK port replicator	
Power Requirements	73.2 watts maximum (19.5V DC/AC100-240V) The notebook supports 50-60 hz and 100-240V AC	
Power Management	Energy Star Compliant Advanced Configuration and Power Interface (ACPI)	
Battery	Lithium-ion	
Dimensions	10.8" (w) × 0.96" (h) × 8.9" (d) (275 mm × 24.5 mm × 226 mm) ^{***}	
Weight	3.75 lbs. (1.7 kg) (with supplied battery)	
Operating Temperature	41° F to 95° F (5° C to 35° C) (temperature gradient less than 18° F (10° C)/hour)	
Operating Humidity	20% to 80% (not condensed), provided that humidity is less than 65% at 95° F (35° C), hygrometer reading of less than 84° F (29° C)	
Storage Temperature	-4° F to 140° F (-20° C to 60° C), temperature gradient less than 18° F (10° C)/hour	

Model	PCG-Z505LE/PCG-Z505LEK	PCG-Z505LS/PCG-Z505LSK
--------------	-------------------------------	-------------------------------

Storage Humidity	10% to 90% not condensed provided that humidity is less than 20% at 140° F (60° C), hygrometer reading of less than 95° F (35° C)	
-------------------------	---	--

* MHz denotes microprocessor internal clock speed; other factors may affect application performance.

† The processor may be reduced to a lower operating speed when operating on battery power.

‡ GB means one billion bytes when referring to hard drive capacity. Accessible capacity may vary.

** Your system may contain additional memory installed at the time of purchase.

†† The PCG-Z505LE/PCG-Z505LEK includes 64 MB memory. The PCG-Z505LS/PCG-Z505LSK includes 128 MB memory.

‡‡ Maximum speed for faxing is 14.4 kbps. Your modem is capable of downloading at 53 kbps. Your online service or Internet Service Provider, however, may not support this technology or operate at this speed.

***Height measured at the thinnest point. Height at the thickest point is 1.15" (29.3 mm).

Specifications are subject to change without notice.

Index

A

AC adapter 21, 22

AC power 21

adding

hardware 59

peripherals 59

printers 70

adjusting

brightness 32

Alt key 30

Application Recovery CDs 94

Applications key 30

attaching port replicator 64

B

batteries 25

using 25

battery pack 22

charging 24

connector 19

indicator light status 24

indicator lights 18, 24, 31

inserting 23

loading 23

power status 24

rechargeable 21

removing 25

battery power 21

brightness

adjusting 28, 32

built-in speaker 18, 32

volume 32

buttons

left 18

right 18

Start (Windows 98) 28

C

cameras

digital video recorder 47

canceling commands 30

Caps Lock 17

indicator light 32

CD Drive 38

CD or DVD Media

cleaning 41

handling 41

CD-ROM discs

inserting 40

CD-ROM drive

closing lid 41

connecting 38, 42

using 38

CDRW Drive 38

charge status indicator light 24

charging battery pack 24

- choosing
 - power source 21
- cleaning
 - CD or DVD Media 41
- cleaning computer 16
- coin-operated telephones 61
- computer 107
 - cleaning 16
 - lithium ion battery 6
 - setting up 17
 - starting 27
 - troubleshooting 95, 104
 - unpacking 12
- connecting
 - CD-ROM drive 38, 42
 - coin-operated telephones 61
 - digital video camera recorder 47
 - floppy disk drive 35
 - monitor 68
 - multiple phone lines 61
 - network 42
 - parallel devices 70
 - party phone lines 61
 - PBX 61
 - phone line 60
 - port replicator 63, 64
 - power source 21
 - printer 70
 - projector 69
- Connecting the CD/CDRW/
DVD Drive 38
- connectors
 - battery 19
 - DC In 19, 21
 - infrared 20
 - monitor 63
 - parallel 70
 - parallel port 63
 - port replicator 19
 - printer 63, 70
 - Serial port 63
 - USB 20, 35
- correction keys 29, 30
- Ctrl key 30
- cursor-movement keys 29
- customer assistance
 - support options 107
- D
- DC In 19, 21
- digital video camera recorder 47
- diskettes
 - ejecting 36
 - handling 37
 - inserting into drive 36
 - troubleshooting 101
- display
 - connector 63
 - options 69
 - selecting 69
- disposal of lithium ion battery 6
- drives 38
 - CD-ROM 38
 - floppy disk 35
- DV In/Out 47
- DVD Drive 38

- DVD-ROM drive tray
 - troubleshooting 102
- DVgate 49
- E
- Eject button 36
- ejecting
 - diskettes 36
- electronic
 - documentation 107
- Energy Star 2
- ergonomic considerations 14
- Escape key 29
- Ethernet network connector 20
- external devices
 - display 66, 68
 - See also monitor
- F
- faxes
 - laws governing 5
- floppy disk drive
 - connecting 35
 - disconnecting 36
 - troubleshooting 101
- Fn key 30
 - combination commands 32
- function keys 30
- G
- Guide Mode 52
- H
- handling
 - CD or DVD Media 41
 - diskettes 37
- hard drive
 - indicator light 18, 31
- hardware
 - online support 107
- headphone
 - connector 19, 69
- help 107
- I
- i.LINK 19, 47, 63
- IEEE1394 19, 47, 63
- indicator lights 31
 - battery 18, 24, 31
 - Caps Lock 17, 32
 - charge status 24
 - hard drive 18, 31
 - Information 18
 - Num Lock 17, 32
 - power 17
 - Scroll Lock 17, 32
- infrared port 20
- input devices 5
- Insert key 29, 30
- inserting
 - battery pack 23
 - diskettes into drive 36
- installing
 - hardware 59
 - peripherals 59
- interference 4
- internal speaker
 - See speakers
- J
- Jog Dial 50

K

keyboard 18, 29–31, 32

L

Launcher Mode 51

LCD

lock lever 27

selecting to display output
69

troubleshooting 99

Left 18

left button 18

lever

LCD 27

Liquid Crystal Display screen

See LCD

lithium ion battery

disposal 6

safety precautions 6

loading

battery pack 23

M

MagicGate 53, 54

mega-bass switch 33

memory

adding 73

Memory Stick card slot 20, 54

Memory Stick cards 53

Memory Stick media

displaying contents 54

microphone 18

troubleshooting 106

microphone connector 19

modem

laws governing 5

troubleshooting 105

monitor 63

connecting 68

connector 69

selecting 69

switching among 32

mouse

troubleshooting 99

mouse properties 34

MovieShaker instructions 83

multiple phone lines 61

N

navigation keys 29

network

connector

See Ethernet network

connector

Num Lock 17

indicator light 32

numeric keypad area 29

O

online

help 107

operator keys 30

output devices 5

adding 70

P

parallel port 63, 70

party phone lines 61

PBX 61

- PC card
 - inserting 42
 - release button 42
 - removing 44
 - slot 42
 - slot protector 42
 - troubleshooting 103
 - Type II 42
- phone
 - connecting line 60
 - jack 60
 - laws governing 5
- port replicator 19
 - connecting 63, 64
- power 31
 - indicator light 17
 - switch 27
- power saving modes 53, 57
 - System Hibernation 33, 57
 - System Idle 33, 57
 - System Suspend 32, 57
 - Video Standby 33
- power sources 21
 - connecting 21
- Print Screen key 30
- printer
 - connecting 70
 - connector 63, 70
 - port 70
- projector 69
- R
- radio interference 4
- rechargeable battery pack 21, 22
- recharging battery pack 24
- Recovery CDs 94
- removing
 - battery pack 25
 - diskettes 36
 - floppy disk drive 36
- restoring data 94
- right button 18
- S
- screen
 - See LCD
- Scroll Lock 17
 - indicator light 32
- selecting
 - display 69
 - LCD 69
 - monitor 69
 - power source 21
- Serial connector 63
- setting up your PC
 - support 107
- setup 15
- Shift key 30
- Shut Down Windows dialog box 28
- Sony Fax-on-Demand service 107
- speakers
 - built-in 18
 - troubleshooting 105
- Start button 28
- starting

- computer 27
- startup problems 28
- switching
 - display 32
 - monitor 32
- System Hibernation mode 33, 57
- System Idle mode 33, 57
- System Recovery CD(s) 91
- System Suspend mode 32, 57

T

- technical support
 - support options 107
- touchpad 18, 34
- troubleshooting 95
 - startup 28, 95
- turning on
 - computer 27

TV

- interference 4

U

- unpacking the computer 12
- USB connector 20, 35, 71
- USB device 71
- Using the Jog Dial Control 52

V

- VAIO® Action Setup 50
- video camera recorder 47
- Video Standby mode 33

W

- Windows 98
 - Explorer 30

- Find window 30
- Help 30
- key 30
- key combinations 30
- Start button 28
- taskbar 28, 97